

PORT WORKS DESIGN MANUAL

PART 5

Guide to Design of Beaches

Civil Engineering Office
Civil Engineering Department
The Government of the Hong Kong Special Administrative Region

© The Government of the Hong Kong Special Administrative Region

First published, June 2003

Continuously updated e-version, June 2023

Prepared by :

Civil Engineering Office,
Civil Engineering Department,
101 Princess Margaret Road,
Homantin, Kowloon,
Hong Kong.

This Port Works Design Manual (PWDM) is a continuously updated version incorporating the PWDM Corrigenda issued since the PWDM was published. This continuously updated version is released in e-format only on the CEDD website. This PWDM is to be cited as “PWDM Part 5 (2023). Guide to Design of Beaches (Continuously updated e-version June 2023). Civil Engineering Office, Civil Engineering and Development Department, HKSAR Government.”

FOREWORD
(Continuously updated e-version Jun 2023)

This continuously updated e-version of the Port Works Design Manual has incorporated the previously issued Corrigendum No. 1/2018 to facilitate the designers and industry practitioners to carry out coastal design in a more convenient manner.

Practitioners are encouraged to comment at any time to the Civil Engineering Office on the contents of this document, so that improvements can be made to future editions.



WONG Chi-pan, Ricky
Head, Civil Engineering Office
June 2023

FOREWORD

The Port Works Design Manual presents recommended standards and methodologies for the design of marine works in Hong Kong. It consists of five separate volumes, namely, Part 1 to Part 5. Part 1 mainly covers design considerations and requirements that are generally applicable to various types of marine works. Part 2 to Part 5 are concerned with specific design aspects of individual types of works including piers, dolphins, reclamations, seawalls, breakwaters and beaches. This Manual supersedes the Port Works Manual prepared in the 80's.

This document, Port Works Design Manual: Part 5, gives guidance and recommendations on the design of beaches. It was prepared by a working committee comprising staff of the Civil Engineering Office and Special Duties Office with reference to the latest local and overseas design publications and experiences in consultation with other Government departments, engineering practitioners and professional bodies. Many individuals and organizations made very useful comments, which have been taken into account in drafting the document. An independent review was undertaken by expert before the document was finalized. All contributions are gratefully acknowledged.

Practitioners are encouraged to comment at any time to the Civil Engineering Office on the contents of this document, so that improvements can be made to future editions.



C C Chan
Head, Civil Engineering Office
April 2003

Working Committee of Port Works Design Manual : Part 5 **[First published Version in 2003]**

The preparation of the document was overseen by Chief Engineer/Technical Services :

Ir Anthony Loo

The document was drafted by the following staff of the Civil Engineering Office :

Ir Lee Wai-ping

Ir Dr Chu Chi-keung

Ir Wong Chi-pan

Assistance and advice were provided by the following staff of the Civil Engineering Office and Special Duties Office :

Ir Chiu Mau-fat

Ir Ko Wai-kuen

Ir Lam Chi-keung

Ir Li Yuen-wing

The document was reviewed by :

Professor Yoshimi Goda, Yokohama National University

Extracts from CIRIA Report 153 “Beach Management Manual” are reproduced by kind permission of CIRIA. This document may be obtained from CIRIA, 6 Storey’s Gate, Westminster, London SW1P 3AU. Extracts from “Coastal Processes with Engineering Applications” are reproduced by kind permission of Professor Robert Dean, University of Florida.

CONTENTS

	Page No.
TITLE PAGE	1
FOREWORD	3
CONTENTS	5
1. INTRODUCTION	9
1.1 Purpose	9
1.2 Definitions and References	10
2. BEACH FEATURES AND PROCESSES	11
2.1 General	11
2.2 Beach Features	11
2.2.1 Shore Profile	11
2.2.2 Beach Sediment Transport	12
2.2.3 Sediment Characteristics	13
2.2.4 Sediment Sizes	13
2.3 Types of Beach Sediment Transport	14
2.3.1 Longshore Transport	14
2.3.2 Cross-shore Transport	14
2.4 Shoreline Evolution	15
2.4.1 Beach Plan Shape	15
2.4.2 Beach Profile	16
2.5 Closure Depth	17
3. DESIGN CONSIDERATIONS	19
3.1 General	19
3.2 Hydrodynamic Conditions	19
3.3 Beach Size	20
3.4 Stability	20
3.5 Sand Retaining Structures	20
3.6 Sand Quality	21
3.7 Sand Placement	22
3.8 Stormwater Drainage	23
3.9 Beach Facilities and Landscaping Features	24
3.10 Environmental Impacts	24

	Page No.
3.11 Post Construction Monitoring	25
4. COLLECTION OF INFORMATION	27
4.1 General	27
4.2 Desk Study	27
4.3 Site Inspections	28
4.4 Ground Investigation and Field Measurements	29
4.5 Mathematical Modelling	30
5. DESIGN METHODOLOGY	31
5.1 General	31
5.2 Fill Quantity	31
5.2.1 Equilibrium Profile Method	31
5.2.2 Equilibrium Slope Method	32
5.2.3 Overfill Ratio Methods	32
5.3 Construction Profile	32
5.4 Equilibrium Beach Profile	33
5.5 Equilibrium Plan Form	34
5.5.1 Coordinate System	35
5.5.2 Longshore Transport Rates and Directions	35
5.5.3 Equilibrium Shoreline Orientation	36
5.5.4 Shoreline Stability	37
5.5.5 Sand Retaining Structures	38
5.6 Mathematical Modelling Report	40
6. POST-CONSTRUCTION MONITORING	43
6.1 General	43
6.2 Frequency and Extent of Monitoring	43
6.3 Monitoring Items	43
REFERENCES	47
TABLES	49
List of Tables	51
Tables	53

	Page No.
FIGURES	55
List of Figures	57
Figures	59
APPENDIX A FILL QUANTITY ESTIMATION	71
APPENDIX B WORKED EXAMPLES	87
GLOSSARY OF TERMS AND SYMBOLS	109

1. INTRODUCTION

1.1 Purpose

The purpose of the Port Works Design Manual (the Manual) is to offer guidance on the design of marine works and structures normally constructed by the Government of the Hong Kong Special Administrative Region. Such works and structures include public piers, ferry piers, dolphins, reclamations, seawalls, breakwaters, pumphouses, beaches and associated marine facilities. The Manual has been written with reference to the local conditions and experience. Therefore, it may also provide a source of useful data and design reference for other marine works and structures constructed by other organizations or parties in Hong Kong.

The Manual is issued in five separate parts. The titles of these parts are :

- Part 1 – General Design Considerations for Marine Works
- Part 2 – Guide to Design of Piers and Dolphins
- Part 3 – Guide to Design of Reclamation
- Part 4 – Guide to Design of Seawalls and Breakwaters
- Part 5 – Guide to Design of Beaches

The recommendations given in the Manual are for guidance only and should not be taken as mandatory. Compliance with these recommendations does not confer immunity from relevant statutory and legal requirements. Because of the variable nature of the marine environment, the design of marine works and structures relies particularly on the use of sound engineering judgement and experience. Practitioners should be aware of the limitations of the assumptions employed in a particular theoretical or computational method. Since the marine environment is a field where active research and development are continuing, it is beyond the scope of the Manual to cover all analysis and design methods. Practitioners should be prepared to explore other methods to suit a particular problem and should also realize that many of the methods will continue to evolve as more data and research findings are available.

This part (Part 5) of the Manual gives guidance and recommendations on the design of beaches for bathing or recreational purposes. It first gives a brief review on the beach processes, followed by guidelines on design considerations, procedures and monitoring methodology. Worked examples are provided in Appendix B to illustrate the application of the design methods. Readers should refer to other parts of the Manual on particular aspects, as necessary.

1.2 Definitions and References

The definitions of terms and meanings of symbols for the purpose of this part of the Manual are given in the Glossary of Terms and Glossary of Symbols at the end of this document. Meaning of symbols not shown in the glossary is given in each case in the text.

The titles of the publications referred to in this part of the Manual are listed in the reference section. Readers should consult these publications for more detailed coverage of particular aspects.

2. BEACH FEATURES AND PROCESSES

2.1 General

It is important to define the terms that are used in coastal engineering to ensure effective communication in beach planning and management. It is also necessary that there is a sound understanding on the dynamic beach processes that are critical to decision making. A summary of the definitions of the commonly used coastal terms and a general description of beach processes are given in this chapter. Variations in water levels and wind speeds may be expected over the design life of the beach as a result of climate change, and beach response should be checked at the beginning and end of the design life of the beach.

2.2 Beach Features

2.2.1 Shore Profile

The shore profile, which is a cross-section taken perpendicular to the shore, is generally composed of the various zones as shown in Figure 1.

The shore is the area extending from the low water line to the point of physiographic change such as a sea cliff and dune field, or where permanent vegetation is established. The shoreline is the intersection between a specified plane of water and the shore. A shore of unconsolidated material, such as sand, is usually called a beach.

The shore can be divided into the foreshore and the backshore. The foreshore, also called the beach face or swash zone, is the area between the mean low water level and the upper limit of ordinary wave wash at high tide. The backshore is the zone of the shore or beach lying between the upper limit of ordinary wave wash at high tide and the coastline. Fine sandy beach material, high storm surge and high wave exposure usually provide the conditions for a wide backshore in a coastal land of low elevation with very mild inclination. However, in a land where hills or mountains start to rise from the coastline or nearby, there can be no chance of having a wide backshore.

The zone that extends seawards from the shoreline to the outermost breaker is the surf zone. Within the surf zone, many waves break because their heights are limited by the local water depth. The width of the surf zone varies with the wave conditions. The littoral zone extends somewhat further seawards beyond the surf zone, and this terminology is used when the process of sediment transport is mainly discussed. Sediment on the surface of seabed is

suspended by breaking waves carried by wave-induced longshore currents. Longshore currents are induced by the combined action of a large number of waves, which break over a wide area of surf zone.

The depth beyond which no significant littoral transports occur is called the closure depth. It can be defined as the depth at the seaward boundary of the littoral zone. The closure depth should best be determined by bathymetric surveys at the site of interest for a sufficiently long period of time. In the absence of survey information, the closure depth d_{oc} , may be determined by the method given in Section 2.5.

Other terms commonly used in coastal engineering include the nearshore and offshore zones. The nearshore zone is often synonymous with the surf zone but it may extend well beyond the zone of breakers. Beyond the nearshore zone is the offshore zone where sediment motions induced by waves effectively cease.

2.2.2 Beach Sediment Transport

The plan shape and cross-shore profile of a beach are continuously subject to changes as a result of wave action that induces sediment transport along and across the beach. Beach sediment transport is the movement of non-cohesive sediment, mainly sand, generally taking place in the surf zone where waves break. The surf zone is the nearshore water area with the most intense beach sediment transport because of the high intensity of the turbulence generated by wave breaking that brings the sediment into suspension. Fine, cohesive materials such as clay and silt, also referred to as mud, are not considered as part of beach sediment transport.

The settling velocity of the transported sediment grains is the major difference between the non-cohesive and cohesive sediment. The settling velocity of sand grains is much higher than that of the mud particles due to their significant size difference. Even when the sand grains are in suspension, they are still close to the seabed because of the relative high settling velocity. If the bathymetric or hydrodynamic conditions change, the sand transport will reflect the change immediately.

Fine, cohesive sediment, however, occurs as fairly evenly suspended sediment over the entire water column, and reacts very slowly to changes in bathymetric and hydrodynamic conditions. The sediment tends to spread over the entire coastal profile under wave actions with a long lag before settlement. Therefore, cohesive sediment only plays an insignificant role in beach sediment transport.

2.2.3 Sediment Characteristics

Sand is a by-product of the weathering of rock; therefore its composition reflects the nature of its origin. In Hong Kong and its vicinity, the erosion of volcanic and granitic mountains and the subsequent transport of the erosion products to the shore by rivers and streams have led to a very significant fraction of the beach sand being composed of quartz with a minor fraction of feldspar. These materials are very hard and resist the abrasion encountered on the trip from the mountains to the beaches, while most of the other less resistant minerals have been abraded to a much greater extent. Eroding coastal headlands and the onshore transport of offshore sediment are other sources of beach sand.

In addition to the quartz and feldspar grains, beach sediment generally contains small amount of heavy minerals such as hornblende, zircon and magnetite. These accessory minerals are denser than quartz and feldspar, and are generally darker in colour. Because of their greater densities and generally smaller diameters, these heavy minerals have different hydraulic behaviour from quartz and feldspar grains. Therefore, they are often concentrated by waves and currents to form dark laminae within the beach sand.

2.2.4 Sediment Sizes

The nomenclature used to classify sediment particles according to grain diameter is described in [Geoguide 3 \(GEO, 2017\)](#). Sand is categorized into coarse, medium or fine grained sand according to the particle size. Geoguide 3 considers any granular particles between 0.06 mm to 2 mm as sand. The particle size distribution of beach sand is generally determined by sieving. The most commonly used parameter to quantify the size of the sand is the median diameter D_{50} , which can be determined directly from the particle size distribution curve.

Offshore sand is often finer than the sand in the nearshore region, which is more dynamic due to the influence of the shoaling and breaking waves. At the breaker line where the turbulence levels are the highest, the grain size reaches a maximum. Across the surf zone, the sand is smaller in size till the swash region where the size increases again. The size can also vary across the dry beach due to the action of winds, which can winnow out the finer sand fractions, and the occurrence of storm waves. The sorting of the sand varies along with the mean diameter and sand often gets well-sorted in regions of high turbulence.

Variation in wave energy reaching the beach will result in variation in sand size and the slope of the beach face. In general, smaller grain diameter of sand can be present with reduced

exposure to waves. With the same sand size, the beach face slope is usually gentler in exposed wave condition.

2.3 Types of Beach Sediment Transport

Beach sediment transport is generally characterised by a combination of sediment moving along the seabed, the so-called bed load transport, and of sediment in suspension, the so-called suspended load. It can be classified as longshore transport and cross-shore transport, and is usually expressed as m³/year.

2.3.1 Longshore Transport

Longshore transport refers to the movement of sediment in the direction parallel to the shoreline. It is mainly due to wave breaking at oblique angles to the shoreline, generating wave-induced currents that transport the sediment in the longshore direction. The direction and magnitude of the longshore currents and hence the transport are governed by parameters including wave height, period and direction, seabed friction and beach slope. Since larger waves break at deeper water and smaller waves break at shallower water, the magnitude of the longshore current and transport vary across the shore as shown in Figure 2.

It should be noted that waves can approach the shore from a wide range of directions, depending on the site conditions. Therefore, longshore transport can take place in either direction of the shore as the directions of incident waves change. The full wave climate in addition to the extreme wave climate should be investigated when calculating the longshore transport. The total annual amount of material transported along the shore, irrespective of directions, is termed the gross longshore transport. The difference between the annual amount of material transported in each direction, or the net results of the 'to' and 'fro' movements of the sediment along the shore, is called the net longshore transport. The net longshore transport is important in assessing the development of the beach plan shape.

2.3.2 Cross-shore Transport

Wave breaking also induces cross-shore transport or onshore-offshore transport in which the movement of sediment is in the direction perpendicular to the shoreline. While longshore transport is the primary mechanism for changes in the plan shape of the beach, cross-shore transport is the means by which the beach profile changes. The response time of beaches to variation in cross-shore transport can be as short as one tidal cycle during storms or as large

as several months with gentle wave conditions. Two types of profiles have been distinguished as shown in Figure 3.

The first type of profile is commonly associated with offshore transport, with sediment being transported seawards. Such profile is usually associated with intense wave conditions, such as those during storms, and the slope in the surf zone is normally gentler. A bar and a trough in its onshore side may form below the water line. The bar, which makes wave breaking to take place further offshore, prevents severe sediment losses in storm conditions. This provides a mechanism for temporary storage of the sediment eroded from the upper portion of the beach profile.

Under calm weather during which mild wave conditions prevail, beach recovery begins. The sediment transported to the lower beach profile during storm events migrates landwards to form another profile, distinguished by a berm at the wave swash limit. Because of this onshore sediment transport, the slope of the beach profile in the surf zone normally becomes steeper.

2.4 Shoreline Evolution

2.4.1 Beach Plan Shape

The significance of longshore sediment transport lies in its effect on the plan shape of the shoreline of beaches. Shoreline changes if there is a gradient in the longshore transport over a stretch of the shore. In simple terms, if the amount of sediment transported into a given section is less than that transported out, erosion will take place. Conversely, sediment accretion will occur if the amount going into the section is greater than that transported out. For example, if a long impermeable structure is built across the shore, variation in the transport rate will occur along the shore near the structure, with the transport rate reduced to zero at the structure. This will lead to sediment accretion on the updrift side and erosion on the downdrift side of the structure as shown in Figure 4.

A beach tends to adjust its shoreline to an orientation parallel to the incoming wave crests so that the longshore transport is minimal. In areas with rocky headlands, this gives rise to the crenulate shaped bay. In a straight, open shore where there is no obstruction, the longshore transport continues uninterrupted and the beach cannot adjust to an orientation that makes the transport rate negligible. However, if a long impermeable structure is constructed across the shore as shown in Figure 4, the longshore transport process is interrupted and the accretion

and erosion portions of the shore near the structure will tend to adjust their alignments parallel to an equilibrium orientation.

It should be noted that the orientation of the beach alignment may vary with time due to variation of wave directions. A dynamic equilibrium of the shoreline orientation exists in which its mean position over a long period of time remains unchanged.

2.4.2 Beach Profile

Cross-shore transport takes place mainly as a result of the change in wave conditions and water levels. Beach profile changes continuously in response to these changes. By averaging these profiles over a long period, a mean profile or equilibrium beach profile can be defined. A simplified description of the equilibrium beach profile is given by Bruun (1954) :

$$d = Ay^{2/3}$$

where d = Water depth at distance y from the shoreline (m).

y = Distance from the shoreline (m).

A = Dimensional factor having unit of length to the one-third power ($m^{1/3}$), mainly depending on the stability characteristics of the bed material.

For information, A can be expressed as (Dean, 1991) :

$$A = 0.21D^{0.48}$$

where D = Grain size in mm.

The equation was derived empirically as an appropriate representation of natural beach profiles averaged over a long time span. It does not exhibit bars and troughs. It simply represents a best-fit description of a profile passing through such features. There are other forms of expression for more complicated cross-shore profiles; further details can be found in CUR (1987).

In reality, the water level and sediment size at a given site can vary and therefore the equilibrium beach profile changes accordingly. Figure 5 shows how the equilibrium profile changes if one of these factors changes. A dynamic equilibrium exists in which the profiles are more or less the same over a long period of time.

2.5 Closure Depth

The estimation of beach fill volume requires the determination of the closure depth. If available, data from profile surveys of seabed at the project site or adjacent locations may be employed to assess the closure depth. The envelope of profile change measured over a time interval of one year or longer can be used to estimate the closure depth associated with wave conditions occurring during the interval. In addition, morphologic features observed on beach profiles such as storm bars and active inner bars can give an indication of the closure depth for different time scales.

In the absence of beach profile data, however, the closure depth d_{oc} measured relative to the mean low water level, may be roughly estimated by the following expression :

$$d_{oc} = 2.28H_e - 68.5 \left(\frac{H_e^2}{gT_e^2} \right)$$

where H_e = Significant wave height being exceeded only 12 hours per year, or which occurs only 0.137 percent of the time per year (m).

T_e = Wave period associated with the above significant wave height (s).

g = Acceleration due to gravity (m/s²).

Variations in water levels and wave conditions may be expected over the design life of the beach as a result of climate change, and closure depth should be checked at the beginning and end of the design life of the beach.

3. DESIGN CONSIDERATIONS

3.1 General

The design principles of a beach nourishment scheme are similar to those of a general marine works project. There are, however, some design aspects or steps that are specific to beach project, and they are highlighted as follows :

- Assessment of the wave, current and bathymetry conditions at the beach to ensure that the beach is safe and suitable for swimming.
- Agreement of the beach size with the client.
- Determination of the sand quality that satisfies the requirements of beach stability, beach users' comfort and aesthetics.
- Design of sand quantity, construction beach profile, equilibrium beach profile and equilibrium plan shape of the beach; the beach area under the equilibrium profile and plan shape should satisfy the beach area specified by the client.
- Design of beach protection structures or sand retaining structures necessary to maintain the stability of the beach.
- Investigation of the acceptability of the hydrodynamic conditions at and around the beach and stability of adjacent shoreline due to the construction of the beach protection structures or sand retaining structures.
- Determination of post-construction monitoring measures for evaluating the effectiveness of beach nourishment.
- Study of the environmental acceptability of the project by carrying out environmental impact study and determine any mitigation measures required.
- Assessment of drainage impact and determination of drainage scheme. Design of beach facilities and landscaping features as required by the client.

3.2 Hydrodynamic Conditions

Beach nourishment can be applied to create a new beach or to widen an existing one to provide more areas for recreation. As a pre-requisite for such purpose, it is necessary to examine whether the wave and current conditions are suitable for leisure and swimming activities, in consultation with the client, beach management authority and relevant government departments. Mathematical modelling (see Section 4.5) can assist in quantifying the wave and current conditions in the nearshore and swimming areas.

3.3 Beach Size

The required beach size is related to its intended usage and should be specified by the client. The calculation of the beach size should be based on the equilibrium plan shape and cross-shore profile of the beach, measured with respect to a certain water level such as the mean sea level.

3.4 Stability

The stability of the beach plan shape and cross-shore profile is an important design consideration. On the basis of a thorough understanding of the hydrodynamic conditions, sediment transport characteristics, seabed geometry and shoreline history at the site of interest, the stability can be examined by means of longshore and cross-shore sediment transport computations. Guidance on assessing the beach stability is given in Chapter 5 of this part of the Manual. Sand retaining structures will be necessary if the computation results indicate that significant sediment loss in either longshore or cross-shore directions will occur without these structures.

Attention should be given to a type of seabed geometry having a sudden increase in water depth or with the presence of a depression where sand transported offshore will be trapped and cannot return to the beach under recovery wave conditions. An example is the presence of an access navigation channel in close proximity to a beach that may act as a sand trap. This kind of geometry should be avoided when choosing the beach location or otherwise sand retaining structures should be built to prevent sand from being transported into these areas.

3.5 Sand Retaining Structures

Sand retaining structures may be constructed to prevent the sand loss from a beach. Typical sand retaining structures include groins, detached breakwaters or underwater sills as shown in Figure 6.

Groins are normally long, narrow structures constructed approximately normal to the shoreline. They function to retain the sand within the beach by acting as a barrier to longshore transport. Breakwaters can also provide protection by reducing the wave energy to reach the shore. They may be constructed in a series of detached short breakwaters to

allow flow circulation to maintain the water quality. These breakwaters, however, may have large visual impact if a high crest level is required to accommodate the waves under high tide. Underwater sills may be designed to reduce offshore losses by supporting the toe of a beach, but experience in other parts of the world suggests that sills are most appropriate for low to moderate wave energy and micro-tidal environments with low net longshore transport. They are not effective to provide protection to the beach during storm events at high water. In high-wave situations, the beach may suffer from a net loss of sand, as the sill may act as a more effective barrier to onshore transport than to offshore transport during low-wave situations after storms and prevent beach recovery to take place.

In a straight, open shore with continuous longshore transport along the shore, sand retaining structures are characterized by being a local solution to beach protection as they will often give problems of shore erosion or accretion on either side of the structures. These structures are more suitable at locations such as those bay areas where longshore transport is localized.

3.6 Sand Quality

The requirements of sand quality for beach nourishment are based on stability, comfort and aesthetics.

The stability is related to the grain size, specific density and shape of individual particles under given wave conditions. Coarser sand will result in a more stable and steeper beach slope, therefore minimizing the required quantity of sand for the nourishment. Turbidity due to wave actions is also reduced. From the stability viewpoint, the specific density should generally be the same or greater than that of the native sand. Typical natural beach slopes for various mean sediment sizes are given in Table 1.

Comfort conflicts with stability, in the sense that from a comfort point of view, beach users preferred finer sand; a balance therefore needs to be struck. The comfort of a beach will also be dependent on the shape of the sand particles; rounded sand is more suitable than angular sand. Minimum shell content is highly desirable.

The aesthetic requirements mainly refer to the colour. Sand with uniform yellowish colour like that of most of the existing beaches is usually preferred.

The sand to be used for a recreational beach should have similar characteristics as those of natural beach sand. The following is some recommendations for selection of sand (DHI, 2001) :

- z The sand should be well sorted; the ratio D_{90}/D_{10} should be lower than 2.
- z The mean grain diameter D_{50} should not be too large because this will generate a steep beach profile. On the other hand, it should not be too small since it will result in a very gentle beach profile. In addition, the beach will not drain properly and will be constantly wet and swampy below the high tide mark if very fine sand is used. Fine sand will also be blown away easily. Ideally, the mean grain diameter should be in the range of 0.25 mm and 0.35 mm if a natural sandy beach is to be obtained.
- z The silt content should be as low as possible, preferably less than 1.0%.
- z The gravel and shell content should be as small as possible, preferably less than 3.0%, as this type of material will be separated out and deposited on the surface of the finer sand.
- z There should be no organic content and contaminated materials.

Sand from borrow area may not be able to meet all the above criteria. Judgement is necessary to determine the suitability of the sand when identifying the borrow area.

3.7 Sand Placement

Generally, sand extracted from a marine borrow area can be placed by means of the following methods (see Figure 7) :

- z Direct dumping from hopper dredgers or barges in the nearshore zone.
- z Pumping from hopper dredgers or barges through floating pipeline to the beach.
- z Spraying from hopper dredgers or barges by rainbow method.

The direct dumping method usually involves fill placement in the nearshore zone where sufficient water depth is available to allow the loaded vessels to enter. By using shallow draft hopper dredgers, it is possible to dump the fill at a minimum water depth of 4 m. However, when sea conditions allow the use of split-hull barges, the water depth can be reduced to 2 m.

Pipeline can be used to pump the sand from the hopper dredgers or barges on the foreshore and backshore of the beach directly. The production rate is dependent on the size of dredgers, shore-vessel distance, sand characteristics and pump capacity. Provision of spare

pipes and pumps is advisable to safeguard a continuous operation in case of breakdown.

The rainbow system involves pumping the sand on the foreshore through a nozzle on the bow of a hopper dredger. This system is usually exploited during calm weather period and when the loaded vessel can approach the foreshore as close as possible. The production efficiency, expressed as the ratio between the material in place and material delivered, may be low due to the possible high losses of the sprayed particles, which can be easily carried away by waves or currents. Distance of spraying normally ranges from about 25 to 75 m.

It should be noted that sand placement too far away from the shore, with the expectation that part of the sand can be transported towards the beach by onshore transport, has generally been ineffective. Past experience has shown that sand placement should be carried out as close to the beach as possible for economic and practical reasons.

Material from a land-based source may also be delivered to site by trucks. However, as large quantity of sand is usually involved in a beach nourishment project, this method may be undesirable from environmental and traffic points of view. It is suitable for rectification of unfilled dry beach area where only small quantity of fill is involved.

Sand placement during the typhoon season should be avoided, as serious sand loss may occur during extreme storm events. If sand retaining structures are built, sand may be placed after completion of these structures to minimize sand loss. For replenishment of existing beaches with a recreational function, the period available for the execution of the replenishment is determined by the end and the start of the swimming season, usually the winter and spring seasons in local conditions. The length of such period will determine the required production rate of the works.

3.8 Storm Water Drainage

Storm water discharging onto the shore will be a cause for hygiene concern due to the possible pollution at the bathing beach area, and will affect the safety of the swimmers because of the likely changing slopes of the seabed induced by the outfall discharge, particularly after heavy rainfall. For these reasons, diversion of the outfalls away from the beach area becomes necessary. An assessment of the catchment area and a study on existing drainage system are required to determine the details of the drainage system and diversion scheme.

3.9 Beach Facilities and Landscaping Features

Facilities such as kiosks, management offices, signs, changing rooms, showers, toilets, lifeguard lookout towers, first-aid rooms, sewage discharge and shark prevention nets should be provided or upgraded for bathing beaches in consultation with the beach management authority and relevant government departments. A separate design is necessary to determine their layouts, structural details and any special installations.

A nourished beach may attract more visitors. Study on the adequacy of existing traffic infrastructure is required to determine if new access roads should be constructed or the existing ones should be upgraded to meet the future need. The need of access facilities such as pedestrian walkways, car parks and coach parking bays should be investigated and designed in consultation with relevant government departments. For remote locations, the provision of a pier for marine access to the beach may be a feasible alternative.

The provision of appropriate landscaping features on bathing beaches such as tree planters and promenade will increase its attractiveness to tourists and beach users. Input from an architect or a landscape architect is advised on this aspect.

3.10 Environmental Impacts

Beach nourishment may have impact on existing marine life. The impact due to sand placement may be short-term, as the marine bottom communities on most beaches survive periodic changes of the seabed elevation related to natural erosion and accretion cycles and storms. It may be possible that the original bio-system can be restored within a short period, as long as the fill material is of similar character to that on the original beach. However, if sand retaining structures are to be constructed, the potential for significant environmental impact will be greater than nourishment scheme without the structures. For example, groins and breakwaters, designed to interrupt longshore sediment transport, may lead to erosion of downdrift shoreline, resulting in loss of land and damage to habitats or features of geological and archaeological interest. These structures may also be visually intrusive and will affect the overall harmony of the surrounding landscape if there is no proper design on aesthetics.

An environmental impact assessment should be carried out to examine the nature of the surrounding environment and shore features, the impact induced by the works, the mitigation measures required, and the means to make the beach and associated structures in harmony

with the surrounding landscape. Details of such assessment are given in the Technical Memorandum on Environmental Impact Assessment Process (EPD, 1997).

3.11 Post-Construction Monitoring

Post-construction monitoring is normally necessary to investigate if the nourished beach behaves in the same way as that predicted in design. Details will be further discussed in Chapter 6 of this part of the Manual.

4. COLLECTION OF INFORMATION

4.1 General

Beaches are constantly changing in response to various coastal processes and factors that control them. Successful design and management of a beach require that the coastal processes and changes be identified at an early stage. This requires sufficient data to assess the beach responses to the hydrodynamic conditions, to identify potential problems, and to determine the future effort in managing the beach. A preliminary assessment of the site is often necessary to devise a suitable data collection programme that should identify the information already available, additional data to be collected or measured, and the level of accuracy and resolution. The data collection programme normally involves the following tasks :

- Desk study.
- Site inspection.
- Ground investigation and field measurements.
- Mathematical modelling.

4.2 Desk Study

Desk study involves analysis of the existing records to develop a general understanding of the hydraulic regime at the site of interest and provide design data for the beach design. The following information research is usually required in the desk study :

- | | |
|--------------------------------|--|
| • Survey plans | – Plan form, orientation and width of existing shore/beach. |
| • Aerial photographs | – Visual information on historical shoreline change. |
| • Satellite imagery | – Hydraulic and sediment conditions over a large area. |
| • Sounding plans | – Bathymetry of the beach area, cross-shore profiles and slopes. |
| • Geological maps | – Type, distribution and size of sediment. |
| • Ground investigation records | – Subsoil profile, strength and other geotechnical parameters. |
| • Meteorological records | – Water levels, currents and wave climate. |
| • Nautical Charts | – Water depth, features at seabed such as |

- Ship information, schedules – presence of local depressions or access channels.
- Drainage and utility records – Type of ships travelling near the site, travelling frequency, information of vessel waves.
- Environmental study reports – Drainage and utility layout, extent of drainage diversion.
- Development plans – Environmental information such as water quality and ecology for environmental impact assessment.
- Future development that may affect hydraulic conditions of the beach site.

The purpose of collecting most of the information listed above are self-explanatory, with the following related to sediment transport highlighted :

- Study of survey plans and aerial photographs will help to build up a time series of shore position. Some features, such as existing piers or jetties, can cause accretion or erosion of beach material, the amount of which may be estimated by analyzing successive maps or photographs. The change in shoreline position, or the beach material eroded or accreted, may indicate the net longshore transport rate and direction at the site. The information is useful for calibrating longshore transport computation.
- Information of sounding plans will provide general indication of the existing cross-shore profile of the nourished beach at the site, including underwater slope and region where sediment transport is taking place (profiles measured at different times reveal fluctuation). The information is useful for assessing the closure depth and the likely shape of future equilibrium cross-shore profile under particular site conditions. Care should be exercised if seabed depression, tidal channels or navigation channels are present as these may become traps of beach sediment.
- Information of vessels travelling near the site is essential to assess whether the beach would be influenced by vessel waves.

4.3 Site Inspections

Site inspections enable visualization of the actual conditions such as the nature of coastal

features, degree of site exposure to waves, extent of surf zone, texture of existing beach materials, effect of marine traffic movements, locations of drainage outfalls and accessibility of the site. Site inspections should be undertaken at periods of both low and high tides in different seasons. The timing of inspections will vary according to the site and the particular concerns of the designer, but it is important to repeat inspections, such as before and after typhoon seasons, to observe natural fluctuations in the shoreline position and the responses of the shore due to storm events. The use of photographs and checklists or record sheets is useful to increase the value of the inspections.

4.4 Ground Investigation and Field Measurements

Additional ground investigation and field measurements should be carried out to supplement the results of desk study and site inspections in order to obtain all data necessary for the design. Fieldwork should be undertaken sufficiently to reveal short-term variations as well as long-term trends.

Specific details and requirements of site investigation and soil testing for marine works are given in Chapter 4 of Part 1 of the Manual. In particular, sampling of sediment should be undertaken to determine the particle size distribution. The extent of sampling should cover potential cross-shore, longshore, vertical and seasonal variations. The size of the sample depends on the particle size and the need to obtain statistical validity; in general, about 1 kg of sample is sufficient for sand. Such information indicates the general spatial particle size distribution in the foreshore and seabed and is useful for choosing the sand size in beach nourishment.

Survey of the shore profile usually comprises surveyed section lines perpendicular to either the shoreline or to a pre-determined baseline. These profiles can be used to quantitatively establish the plan form of the shore, shore behaviours due to storm events and potential envelope for cross-shore profile evaluation. They may be able to provide an indication of the order of sediment transport volume. When establishing profile lines or station points, it is important to ensure that they can be easily re-established for successive surveys. The density of the lines should provide adequate coverage of the foreshore and seabed. Supplementary shore parallel profiles are useful to provide additional level information along the shore. Shore profile surveys should be combined with nearshore bathymetric surveys to assess the extent of wave influence on the sea bottom.

Current and wave measurements, as described in Chapter 2 of Part 1 of the Manual, should be

carried out if existing data are not adequate. Attention should be paid to sites located near fairways, access channels or piers where marine traffic movements or berthing will generate vessel waves on the shore. A survey on the marine traffic, such as types of vessels, movement patterns and travelling speeds, should be carried out to assess the vessel wave climate at the site. Environmental impact assessment should be carried out with reference to the Technical Memorandum on Environmental Impact Assessment Process (EPD, 1997).

4.5 Mathematical Modelling

Mathematical modelling is normally required to assist in determining the wave climate and flow conditions. For details of wave and current predictions by mathematical modelling, reference should be made to Chapter 2 of Part 1 of the Manual.

A yearly wave climate, both due to winds or vessel movements, is necessary in addition to waves under extreme conditions. The yearly wave climate is required to assess the long-term plan form of the beach, as all wave components will contribute to the longshore transport. It is normally expressed as a wave rose (see Figure 8) or a wave height table that describes the wave heights and their duration of occurrence in different directions. The yearly wave climate will also provide information to estimate beach recovery under mild wave conditions. Extreme wave conditions are required to determine the extent of beach erosion during storm events.

Tidal currents may have impact on longshore transport, although they normally contribute to a much smaller extent than the longshore current. Typical tidal current information under spring and neap tides in different seasons should be computed to assess their impact on sediment transport.

5. DESIGN METHODOLOGY

5.1 General

This chapter gives guidance on the estimation of beach dimensions, assessment of fill stability and design of sand retaining structures. It should be noted that the processes in nature which cause reshaping of the beach fill are complex, and quantitative formulation of such deformations available nowadays are still not very accurate. Hence, the computations can only yield approximate figures. It is worthwhile to investigate the performance of previous beach nourishment schemes under similar site conditions for reference in design.

5.2 Fill Quantity

Several analytical methods to estimate the fill quantity are given (CIRIA, 1996) for preliminary design purpose. These methods take into account the reshaping of beach profile and sediment losses. However, none of these methods should be used in isolation. Instead, they should be used together to indicate the potential range of fill volumes. General descriptions of the principles of these methods are given in the following paragraphs and details of the formulae are described in Appendix A. The estimated fill quantity may be used as a starting point of determining the construction profile and equilibrium profile of the beach. A worked example is given in Appendix B to illustrate the use of these methods.

It should be noted that loss of fill may occur due to actions of waves and currents during fill placement. The actual fill quantity required may be more than the quantity estimated by these methods.

5.2.1 Equilibrium Profile Method

Dean's equilibrium profile method (see Section A.2 of Appendix A) estimates the fill volume of a given grain size to produce a desired width of beach per unit length of the shoreline after the profile has reached equilibrium. This method considers three types of nourished profile that depends on the size of the fill and native beach sediment. Having determined the type of nourished profile by means of the Dean formulae, the volume of fill can be calculated from the formulae given in the method.

5.2.2 Equilibrium Slope Method

The equilibrium slope method by Pilarczyk, Van Overeem and Bakker (see Section A.3 of Appendix A) considers the reshaping of the active profile in response to prevailing hydraulic conditions and the depth to which the profile will develop. The recharged profile is based on the present native profile, but if the grain size of the recharge fill is different, the profile steepness will be adjusted according to the fall velocities of the native and recharge materials. Similar to the Dean method, the volume of fill can be determined after the recharge profile is determined.

5.2.3 Overfill Ratio Methods

The overfill ratio methods (see Section A.4 of Appendix A) assume that the native material at any particular site represents the most stable sediment grading for the environmental conditions of the site. The fill for beach nourishment will be sorted by the wave and tidal processes and will eventually adopt a grain size distribution similar to that of the native material. Under such assumptions, these methods quantify the extent of overfill required to compensate the losses of fill. These methods include the Krumbein-James Method and the Dean Method. The methodology involves multiplying the required volume of beach material by an overfill ratio to determine the quantity of recharge material over that required by the dimensions of the proposed recharge works.

5.3 Construction Profile

When constructing a beach, fill placement in strict accordance with the design beach profile may not be practical and cost effective, as the equilibrium cross-shore profile may extend very far away from the shore (see Chapter 3). A usual practice is to build up a construction profile (see Figure 9) at the upper portion of the existing beach profile, allowing wave action to shape the beach slope to equilibrium. The following steps may be applied to design the construction profile :

- Determine the fill volume according to Section 5.2 above.
- Assume a berm width of the construction profile, which should be greater than
- the beach width of the equilibrium beach profile. The beach width of the equilibrium beach profile should meet the beach width requirement of the client.
- Assume an elevation of the berm of the construction profile with reference to

the levels of existing ground.

- Assume a fill slope of the construction profile, which is normally steeper than the slope of the equilibrium beach profile.
- Determine a preliminary construction profile from the fill volume, berm width, berm elevation, fill slope and the existing seabed profile.
- Refine the construction profile based on subsequent assessment of the equilibrium beach profile (see Section 5.4).

As a general indication, the slopes of the construction profile normally lie within the following ranges :

<i>Median Grain Size of Sand D_{50} (mm)</i>	<i>Upper Slope</i>	<i>Lower Slope</i>
Less than 0.2	1:20 to 1:15	1:35 to 1:20
Between 0.2 and 0.5	1:15 to 1:10	1:20 to 1:15
Greater than 0.5	1:10 to 1:7.5	1:15 to 1:10

The upper slope can be interpreted as the portion between the crest of the berm and the mean low water level while the lower slope is the portion from the low water level to the point of intersection of the construction profile and the existing beach profile.

Strict adherence to the slope of the construction profile during nourishment is not an absolute requirement if the placed fill seeks to attain a different adjusted slope. Adjustment can be made to the berm width of the construction profile to allow for the difference between the assumed and actual slopes. This will prevent unnecessary time to mold the beach in the dynamic region of the profile. Placement of the designed fill volume is more important than matching a construction profile exactly.

A worked example is given in Appendix B to illustrate the calculation of the construction profile.

5.4 Equilibrium Beach Profile

Mathematical models on cross-shore transport may be applied to determine the equilibrium profile of the beach. These models calculate the water movements first, then the sediment transport they produce and finally the change in profile by solving differential equations

involving continuity, energy and momentum with the aid of numerical methods. General input data for determining the equilibrium profile are shown in Table 2. Details of the input requirements and formats, however, are dependent on the type of modelling software adopted. Therefore, reference should be made to the user's manuals of the software before commencing the computations. General reporting requirements of using mathematical models are described in Section 5.6 of this Chapter.

The construction profile may be adopted as the starting point of profile analysis using mathematical models. It can be subject to computation runs under extreme and normal wave conditions. The input water levels should correspond to the chosen wave conditions. The computed equilibrium profile under normal condition may then be used as the input profile to re-compute the equilibrium profile under extreme condition and vice versa. Such step may be further iterated to assess the final equilibrium profile. The width of the beach under equilibrium should satisfy the client requirements.

Where a deep channel exists close to the beach, it is necessary to check whether the lower portion of the equilibrium profile will lie close to or even fall over the channel. If it is the case, the sand in the lower portion of the profile will fall into the channel. The sand will be either trapped inside the channel or drifted away by tidal currents. Under such situation, a stable beach cannot be formed.

5.5 Equilibrium Plan Form

The stability of the shoreline can be assessed using longshore transport mathematical models. The computations normally involve the following steps :

- Setting up of a coordinate system.
- Computation of longshore transport rates and directions.
- Computation of equilibrium shoreline orientation.
- Assessment of shoreline stability.
- Determination of the layout of sand retaining structures if necessary.

Typical input data required for shoreline computations are shown in Table 2. However, reference should be made to the user's manuals of the software before commencing the computations as details of the input requirements and formats depend on the type of software adopted. General reporting requirements of using mathematical models are detailed in Section 5.6 of this Chapter. Particular aspects of shoreline computations are given in the

following paragraphs.

5.5.1 Coordinate System

Shoreline computations involve the determination of longshore transport rates and directions due to different incoming wave conditions in different periods. As longshore transport can take place in either directions of the shore, it is necessary to set up a coordinate system to avoid confusion of directions in longshore transport computations. The coordinate system defines the sign conventions of incident wave angles and longshore transport directions. The original shoreline is usually chosen for convenience as the x-axis. The y-axis takes account of the variability of longshore transport perpendicular to the shore. As longshore transport is related to long-term change of the shoreline, the mean sea level may be taken as the zero reference datum for the vertical z-axis. An example of the coordinate system is shown in Figure 10.

5.5.2 Longshore Transport Rates and Directions

A number of longshore transport formulae have been developed to calculate the longshore transport rates and directions at a point of the shore. An example is the CERC formula, which can be written as follows (CUR, 1987) :

$$s_l = BH_o^2 c_o K_{rb}^2 \sin \phi_b \cos \phi_b$$

or
$$s_l = BH_b^2 c_b \sin 2\phi_b$$

where s_l = longshore transport due to breaking waves.

B = a constant equal to about 0.025.

H_o = deepwater significant wave height.

H_b = significant wave height at breaker line.

c_o = deepwater wave velocity.

c_b = wave velocity at the breaker line.

K_{rb} = refraction coefficient at the breaker line.

ϕ_b = wave angle at breaker line.

Other longshore transport formulae include those developed by Bijker, Van Rijn, Bailard and so forth. Longshore transport models are normally equipped with these formulae for designers to apply in the computations. More details of these formulae can be found in

CUR (1987). It should be noted that different formulae will likely give different longshore transport quantities even using the same input data, due to their difference in theoretical basis. Trial runs are required to examine if a particular formula is applicable to the site with reference to observations or field measurements. Alternatively, the results of these formulae may indicate the potential range of longshore transport quantities.

Each wave condition of the wave climate, comprising wave height, period, incident wave angle and duration of occurrence, should be applied to calculate the net longshore transport. The net longshore transport is given by :

$$S_l = \sum_i^n s_{li} \cdot p_i$$

where S_l = Net longshore transport (m³/year).
 s_{li} = Longshore transport due to wave condition i computed by a longshore transport formula (m³/s); the direction of s_{li} being dependent on the incident wave angle with respect to the shore normal as defined in the coordinate system.
 p_i = Duration of occurrence of wave condition i in a year (s).

The sign of the net longshore transport S_l gives the direction of the net longshore transport.

A worked example is given in Appendix B to illustrate the principle of estimating the longshore sediment transport.

The rate and direction of longshore transport varies with the orientation of the shoreline. Therefore, the calculation of the longshore transport needs to be carried out at different locations of a shoreline with variable orientation. Such calculation, however, is normally automatically included in a mathematical modelling software.

5.5.3 Equilibrium Shoreline Orientation

The equilibrium shoreline orientation can be determined by plotting the longshore transport rates under different shoreline orientations against the shoreline orientations. The orientation corresponds to zero net longshore transport as shown on the plot is the equilibrium shoreline orientation (see Figure 11). The alignment of the nourished beach will gradually be modified by wave actions to reach the equilibrium orientation, if headlands or sand retaining structures are present.

There may be two shoreline orientations corresponding to zero net longshore transport if the net longshore transports for various shoreline orientations are plotted against the shoreline orientations, as shown in Figure 11. The equilibrium shoreline orientation should be the one that is normal to the resultant incoming wave angle causing the net longshore transport direction at the shoreline of the site. A worked example is given in Appendix B to illustrate the principle of estimating the equilibrium orientation.

5.5.4 Shoreline Stability

Longshore transport mathematical models, in addition to calculating longshore transport rate, direction and equilibrium shoreline orientation, are normally equipped with functions to compute shoreline evolution. If sand retaining structures (see Section 5.5.5) are required to protect the shoreline, their layouts can be input in the models to check for their effectiveness in maintaining the shoreline stability.

The simplest form of these models is based on the one-line approach that predicts the changing position of a single representative beach contour under which the beach profile will advance or retreat by the same amount at all depths (see Figure 12). This type of models can provide a rough schematization of the shoreline change and can only deal with a nearly straight beach. A better schematization is given by the multi-line approach. The multi-line approach is similar to the one-line approach except that it takes into account the cross-shore transport across two or more zones of the profile (also see Figure 12). Models of the multi-line approach are also limited to nearly straight beaches but can provide better estimation of the shore response in problems such as the performance of headlands or groin-type structures in retaining beach material. For more complicated shoreline configurations, process-based morphological space response models with full integration of the cross-shore and longshore responses with the spatial hydrodynamic conditions may provide better description of the shoreline evolution. This type of models requires more detailed description of waves, tidal currents, water levels and sediment characteristics, and more sophisticated software and computational effort are required.

The choice of the type of models for simulating the shoreline behaviour is a matter of engineering judgement, depending on the site conditions, the information to be obtained from the models, and a balance of computational effort and accuracy required.

5.5.5 Sand Retaining Structures

Where sand retaining structures are found to be required to maintain the stability of the beach, the following rules may be adopted as a starting point to assess the effectiveness of their layouts by mathematical models. More details can be found in CIRIA (1996), Dean and Dalrymple (2002) and Silvester and Hsu (1993).

(1) Groins

Groins will result in sand accumulation and lee side erosion, leading to an equilibrium plan form as shown in Figure 13. The effectiveness of groins in maintaining the required beach area will be affected by their length, spacing, orientation and crest elevation.

As an initial estimate, a wave height and period representing the moderate wave climate during which the beach is building up may be chosen to calculate the position of the breaker zone at mean high water level. The groin length may be taken as the seaward limit of this zone. The spacing of groins is related to their length. Experience elsewhere in the world shows that the spacing/length ratio varies considerably from 0.5 to 4, but ratio in the range of 1 to 2 may be assumed in the initial runs of mathematical modelling.

Groins slightly away from the perpendicular of the shoreline and in the direction of longshore transport are capable of providing more effective control of longshore transport. However, when wave directions are variable, resulting in longshore transport in either direction of the shore, groins perpendicular to the shoreline are more appropriate.

As sand is transported in suspension throughout the water column, a higher groin crest level will have more impact on longshore transport. Some guidelines on the determination of the groin crest level are given in CIRIA (1996). Marine Department's advice on navigational safety should be sought if the groin crest level seaward beyond the backshore is below the water surface.

It should be noted that, if only perpendicular groin structures are constructed for a recreational beach, there is a possibility that changes in wave direction will cause sand fill to be lost around the tips of the structures. In addition, if the sand fill is finer than the native sand, it will move offshore and will be lost around the tips of the structures. In such case, T groins, sometimes with sills connecting the ends, may be used (see Figures 16 and 17). This method, with the advantage of controlling the amount of wave energy at the created beach, may be considered in beach design.

(2) Detached Breakwaters

A primary consideration in the design of detached breakwaters for a beach project is the desired plan form and beach width behind the breakwater. If a breakwater is close to the shore and long with respect to the wavelength of the incident waves, sand will continue to accumulate behind the breakwater until it connects with the breakwater; this is called a tombolo (see Figure 14). If the breakwater is far from the shore and short with respect to the wavelength of the incident waves, the shoreline will build seawards, but is prevented by wave action and longshore currents from connecting with the breakwater. The shoreline bulge that forms is termed a salient.

An important design parameter is the amplitude of the salient y_s (see Figure 14), as it is a measure of the amount of beach created by the breakwater. Hsu and Silvester (1990) developed equations showing the relationship of y_s/y_B (ratio of salient amplitude to breakwater distance from shoreline) and y_B/L_B (ratio of breakwater distance from shoreline to breakwater length). Dean and Dalrymple (2002) prepared Figure 14 based on the formula proposed by Hsu and Silvester. The curve yields some interesting results that if the breakwater is located at a distance offshore greater than about 6 times its length, it will have no effect on the shoreline. A tombolo may be formed for y_B/L_B less than 1. Therefore, the curve may be unreliable for small values of y_B/L_B .

For multiple detached breakwaters, the gap width between breakwaters will also affect the form of the shoreline within the breakwaters. Generally, the gap width should be larger than the length of the breakwaters if no tombolo is to be formed, but should not be too large that the interaction between breakwaters disappears or each breakwater will simply act as a single offshore structure. More information on the gap width between breakwaters are given in Dean and Dalrymple (2002).

(3) Artificial Headlands

Silvester and Hsu (CIRIA, 1996) developed design curves for the calculation of the final equilibrium plan shape of a beach contained within headlands from observations or measurements of natural crenulate bays which appear to be in equilibrium with the incident wave climate. The method is based on the principle that waves dominating the longshore transport for the stretch of coast are diffracted around the upcoast headland and refracted in such a way as to arrive normal to the shoreline of the bay along its entire periphery. Longshore transport is therefore reduced to a minimum and the shoreline remains stable with

respect to longshore transport. Details of the method are shown in Figure 15. The method may be used to examine whether a new shoreline due to a seaward extension of the existing beach can still be enclosed by the headlands. If the new shoreline cannot be enclosed by the headland, this indicates that sand retaining structures should be constructed at the headlands to prevent sand loss through longshore transport. Groins may also be connected to detached breakwaters to form artificial headlands as shown in Figure 16. Groins can be of different length so that the resulting crenulate bay can be shaped to suit different design configurations.

A worked example is given in Appendix B to show the application of the method.

(4) Underwater Sills

Sills are designed partly to reduce the intensity of inshore wave climates and partly to act as physical barriers to cross-shore transport of beach material. They are, however, only able to influence the sediment transport processes in their lee when they cause wave breaking. As a general rule for determining the preliminary layout, the depth of water over the crest should be less than $H_s/0.55$ (CIRIA, 1996), where H_s is the significant height. Under local conditions with large tidal range, sills should have to be constructed with a crest level close to high water, and will therefore be exposed over most of the tidal cycle. However, this may have potential visual impact. Sills with lower crest elevations cannot provide any significant shoreline protection during storm events at high water. In high-wave situations, sills may even suffer from a net loss of beach material as the structure may act as a more effective barrier to onshore transport than to offshore, preventing beach recovery to take place. Where necessary, they may be used in conjunction with groins or detached breakwaters to provide extra protection to the beach. Guideline for determining the preliminary layout is given in Figure 17.

5.6 Mathematical Modelling Report

Computations of shoreline and profile responses of beach can be efficiently carried out by means of mathematical models. As various types of models of different organizations may be developed on different theoretical basis and computational accuracy, a modelling report should be prepared to describe the modelling approach, procedures and results so that decision makers can assess the reliability of the modelling results. A modelling report should include the following information :

- Types of beach models employed, including principles, assumptions, range of applicability, limitations and accuracy achieved.
- Types of wave transformation models including the specification of waves (whether monochromatic or directionally spectral).
- Site conditions, including wave climate, shoreline configuration, bathymetry, water levels and current conditions.
- Model set-up, including the beach schematization, design conditions, model boundary conditions and input data.
- Model calibration, including results of trial runs, comparison of results with field observations or measurements and sensitivity analysis of input data.
- Scenarios adopted in the simulation, including the use of sand retaining structures.
- Computations, including summary of various input conditions and computation results.
- Conclusions, including equilibrium beach conditions and layout of sand retaining structures.

Where necessary, specialist advice or input should be sought in the beach modelling.

The calculation of the equilibrium plan form and cross-shore profile of a beach is subject to many variables from wave conditions and bathymetry to analytical method and beach protection measures. Individual computations should therefore be checked for consistency among the calculated equilibrium shapes and compared with the actual site conditions to ensure that the equilibrium shapes are realistic and achievable. This process may involve checking on the following :

- Whether the final plan shape of the beach is consistent with the prevailing wave direction.
- Whether the equilibrium plan shape or profile of the replenished beach is compatible with similar existing beaches.
- Based on the final plan shape of the beach, whether the toe of the equilibrium cross-shore profile is contained within headlands or sand retaining structures; otherwise, there will be sand loss from the toe of the beach.
- Whether the client requirement, such as beach area or width, are satisfied under the equilibrium beach condition.
- Whether the equilibrium profile will be too close to navigation channel or seabed depression, as there is a risk of sand loss into these areas, in particular during typhoon periods.

An overall summary of the computations and interpretation with reference to the site conditions should be given in the design report to indicate the validity of the predicted beach plan forms and profiles.

6. POST-CONSTRUCTON MONITORING

6.1 General

The dynamic nature of beaches makes post-construction monitoring of artificially nourished beaches essential. A monitoring programme should normally be set up to identify change and trend in beach alignment, profile and fill volume, to determine when and where fill recharging is necessary, and to assess the effectiveness of any action taken. The requirements of the monitoring programme should be determined during the design stage of the beach project.

6.2 Frequency and Extent of Monitoring

No strict guidelines can be presented regarding the measurements to be carried out in such a monitoring programme. In particular, the fineness of the measuring grid and the frequency of measurements are largely dependent on local conditions. At the start of the programme, these measurements should be carried out quite frequently, say every three months, as the largest changes usually occur in such period. The frequency of the measurements may be changed to roughly twice or once a year, say in the second and third year, and may be further reduced subsequently, depending on the stability of the observed beach conditions. It is advisable that measurements should also be carried out immediately after storm events during the initial service life of the beach to assess the beach responses under extreme conditions.

The extent of measurements should cover the area where significant changes due to the beach fill may take place. This means that measurements should extend seawards to where no changes in the bathymetry are expected. The measurements should include adjacent shores that may be affected by the new beach, such as deposition of sand transported from the beach or possible shoreline erosion. The distance between the measurement positions should reflect sufficient accuracy on any change in beach plan form, profile and fill volume.

6.3 Monitoring Items

Sounding surveys and topographic surveys should be carried out to determine the evolution of the beach. Critical profile may be set up as shown in Figure 18 as an indicator to determine if actions such as re-nourishment should be taken against beach erosion. Important parameters of the profile, such as crest elevation or width of dry beach area, should

be agreed with the client. To enable better understanding of the profile behaviour, such as the fill volume change, the profile may be further divided into portions, such as above high water, high water to low water, and below low water. Results of the surveys should be stored in a database where the following information can be determined :

- Change in volume of fill in different vertical portions of the beach profile.
- Comparison of beach levels and widths with expected values.
- Trends in these quantities compared with expected trends.
- Rate of longshore transport as compared with the expected one.
- Effect on adjacent shores.

Aerial photographs can be used to assist in the interpretation of topographic and sounding survey results, particularly in the identification of areas of erosion or sedimentation and the provision of an overall view on any shoreline change. Aerial photographs of most areas of the territory can normally be obtained from the Survey and Mapping Office, Lands Department.

The collection and analysis of particle size distribution of sediment samples, both temporally and spatially, will provide information on how different sand sizes are re-distributed over the beach profile and whether beach material is being carried over sand retaining structures. Sediment sampling can help to identify whether the recharged material is appropriate, or whether a finer or coarser material should be used in future replenishment.

Water level, current, wind and wave data should be available to correlate the meteorological conditions with the change in nourished beach shape and profile as well as any detected sand movement. They are useful to verify the beach design and to evaluate the future fill recharging strategy.

In addition to beach monitoring, structural monitoring should be carried out for those sand retaining structures to identify gradual deterioration and dislocation which may continue unnoticed; this is important to the safety of the swimmers in the bathing area. Typical monitoring methods may include diving inspection, bathymetric surveys and aerial photography. Monitoring frequency and schedule should be agreed with the maintenance authority of these marine structures.

As a final remark, a decision on whether the collection of a particular type of field data in a monitoring programme should be continued will depend on the specific character of the site and if extra data will be useful to the beach management. For example, on a beach that is

stable or accreting, it may not be necessary to continue the monitoring, although it is prudent to review the situation later. Therefore, it is a good practice to review the monitoring practice every several years in order to obtain the information needed in the most cost-effective manner.

REFERENCES

- Bruun, P. (1954). Coast erosion and the development of beach profiles : Technical Memorandum No. 44, U S Army Corps of Engineers, Beach Erosion Board, Washington DC.
- CIRIA (1996). Report 153 – Beach Management Manual. Construction Industry Research and Information Association, United Kingdom, 448p.
- CUR (1987). Report 130 – Manual on Artificial Beach Nourishment. Centre for Civil Engineering Research, Codes and Specifications, the Netherlands, 195p.
- Dean, R.G. (1991). Equilibrium beach profiles : Characteristics and applications. Journal of Coastal Research, Volume 7, No. 1, pp. 53-84.
- Dean, R.G. and R.A. Dalrymple (2002). Coastal Processes with Engineering Applications. Cambridge University Press, 475p.
- DHI (2001). Shoreline Management Guidelines. Danish Hydraulic Institute, Denmark, 232p.
- EPD (1997). Technical Memorandum on Environmental Impact Assessment Process. Environmental Protection Department, Hong Kong, 83p.
- GEO (2017). Guide to Rock and Soil Descriptions (Geoguide 3) (Continuously Updated E-Version released on 29 August 2017). Geotechnical Engineering Office, Civil Engineering and Development Department, HKSAR Government, 171 p.
- Hsu, J.R.C. and R. Silvester (1990). Accretion behind single offshore breakwater. Journal of Waterway, Port, Coastal, and Ocean Engineering, ASCE 116, pp. 362-380.
- Silvester, R. and J.R.C. Hsu (1993). Coastal Stabilization. World Scientific, Singapore, 578p.

TABLES

LIST OF TABLES

Table No.		Page No.
1	Typical Natural Beach Slopes for Various Sediment Sizes	53
2	Typical Data for Cross-shore and Longshore Transport Computations	53

Table 1 Typical Natural Beach Slopes for Various Sediment Sizes

Median Sediment Sizes D_{50} (mm)	Mean Beach Slope
0.2	1:50 – 1:100
0.3	1:25 – 1:50
0.5	1:20 – 1:40
5.0	1:8 – 1: 15
Note : 1. A beach of a given grain size will adopt a flatter slope in an area exposed to severe waves than in an area exposed to moderate waves. 2. For slope of construction profiles, refer to Section 5.3.	

Table 2 Typical Data for Cross-shore and Longshore Transport Computations

Type of Sediment Transport	Type of Data
Cross-shore Transport	<ul style="list-style-type: none"> ● Prevailing wave height, period, direction and duration under normal weather conditions in different seasons ● Extreme wave height, period, direction and duration under storm conditions ● Water level (mean sea level and extreme sea level) ● Construction beach profile ● Sediment size (usually median grain diameter) and density ● Required beach width
Longshore Transport	<ul style="list-style-type: none"> ● Wave climate (wave height, period, direction and duration of occurrence), including wind waves and vessel waves ● Water level (mean sea level, mean high water level and mean low water level) ● Bathymetry (cross-shore profile : initial beach profile and equilibrium beach profile) ● Sediment size and density ● Length of shoreline ● Orientation of beach ● Required beach width ● Current (usually speed and direction at model boundary) ● Shoreline characteristics or longshore transport quantity at model boundary ● Layout of sand retaining or beach protection structures, if any

FIGURES

LIST OF FIGURES

Figure No.		Page No.
1	Schematic View of Shore Profile	59
2	Longshore Current and Longshore Sediment Transport	59
3	Beach Profiles	60
4	Effect of Coastal Structure on Beach Plan Shape	60
5	Variation of Equilibrium Beach Profiles	61
6	Beach Protection Measures	61
7	Sand Placement Methods	62
8	Wave Rose	63
9	Construction Profile	63
10	Coordinate System for Longshore Transport Computation	64
11	Variation of Net Longshore Transport with Shoreline Orientation	64
12	One-line Approach and Multi-line Approach	65
13	Groins	66
14	Detached Breakwaters	67
15	Artificial Headlands	68
16	Formation of Artificial Headlands by Groins and Detached Breakwaters	69
17	Configuration of Underwater Sill and Associated Sand Beach of Relatively Mild Slope	69

Figure No.		Page No.
18	Monitoring of Beach Profiles	70

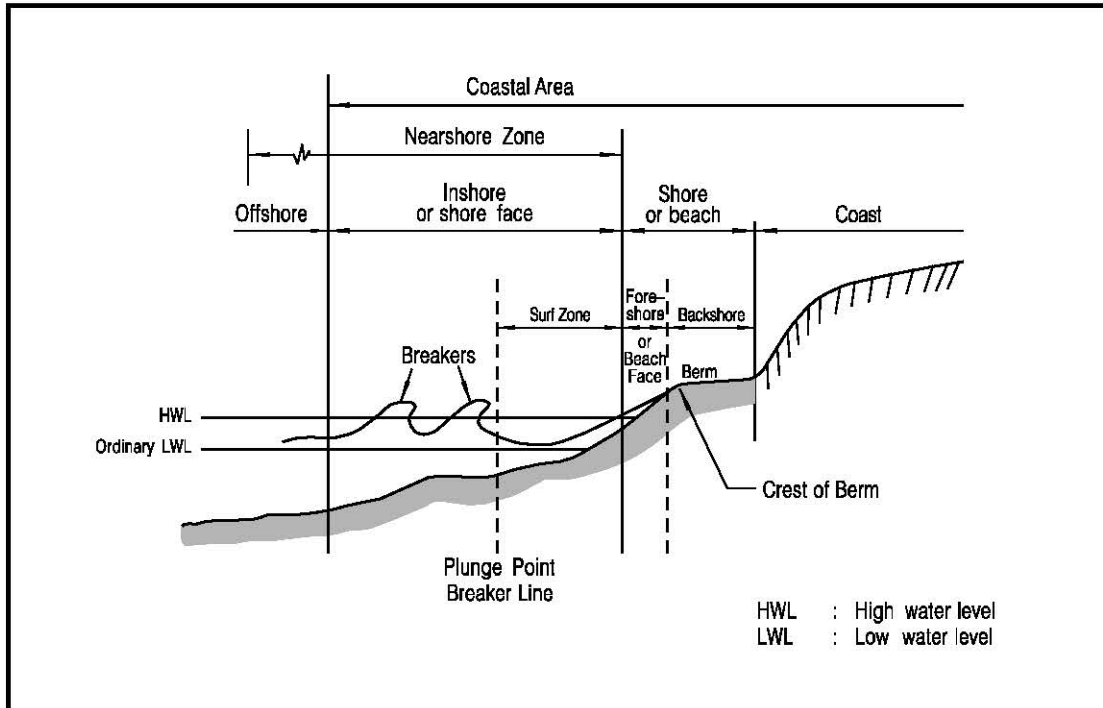

Figure 1 – Schematic View of Shore Profile

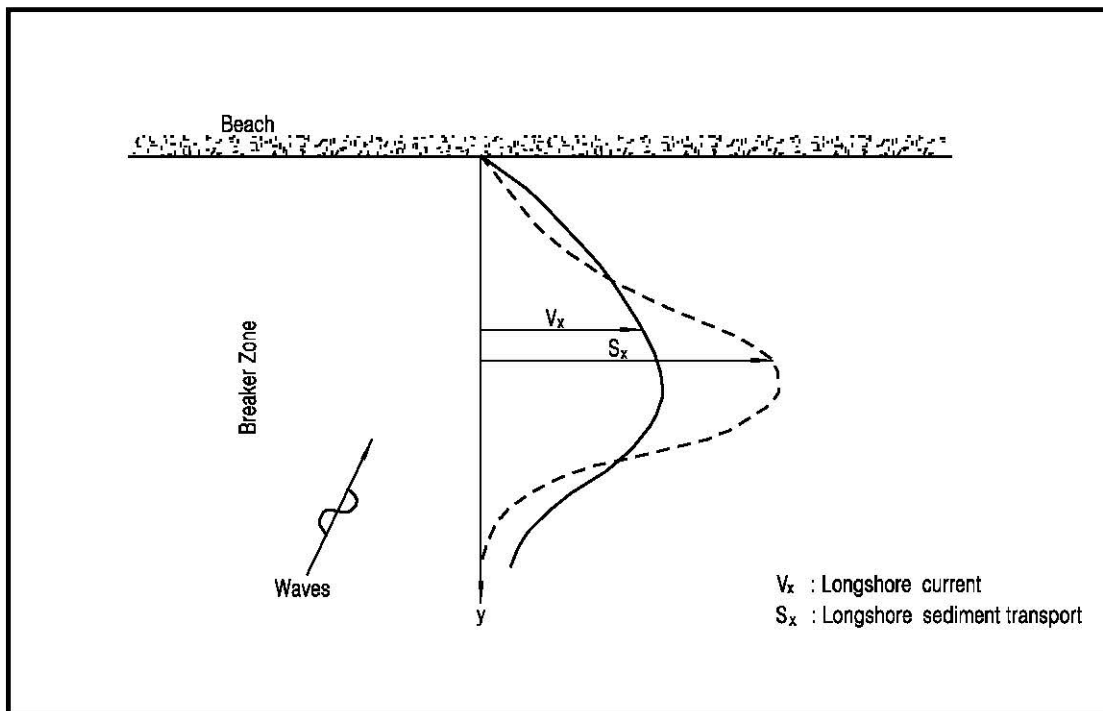

Figure 2 – Longshore Current and Longshore Sediment Transport

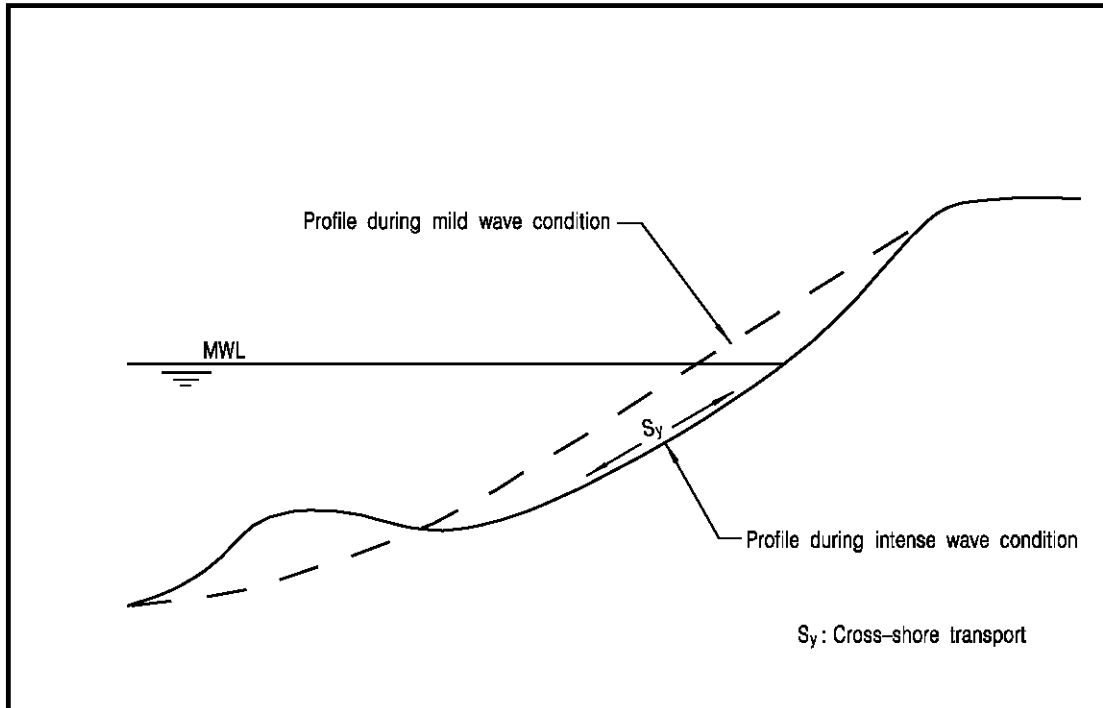

Figure 3 – Beach Profiles

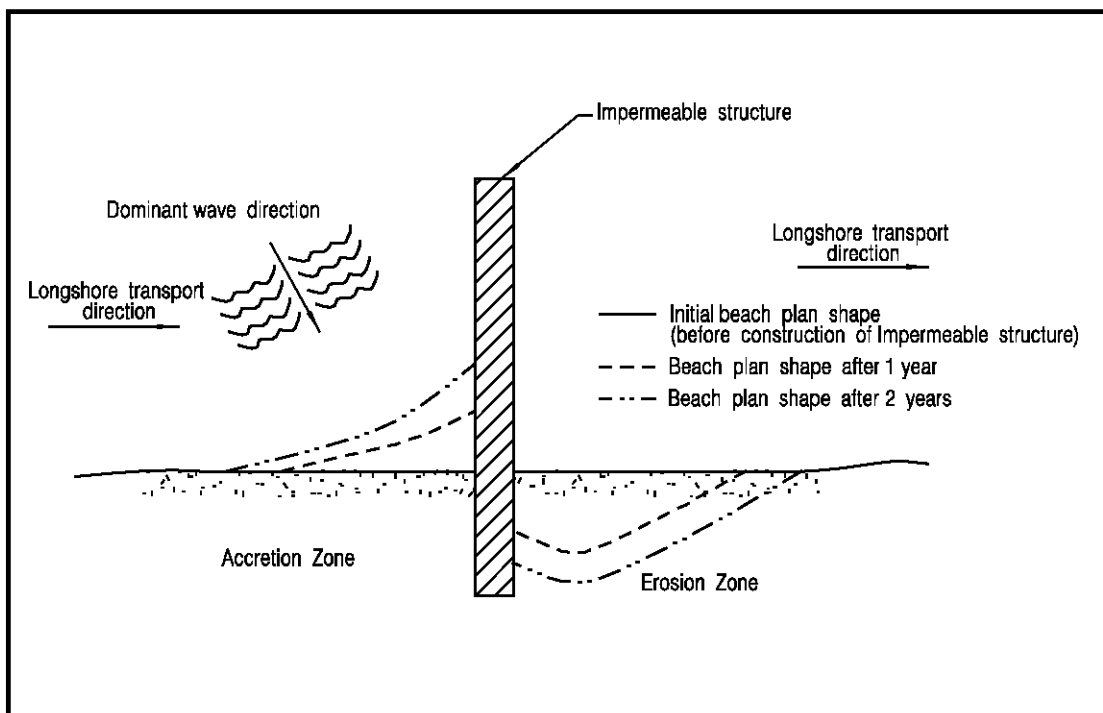

Figure 4 – Effect of Coastal Structure on Beach Plan Shape

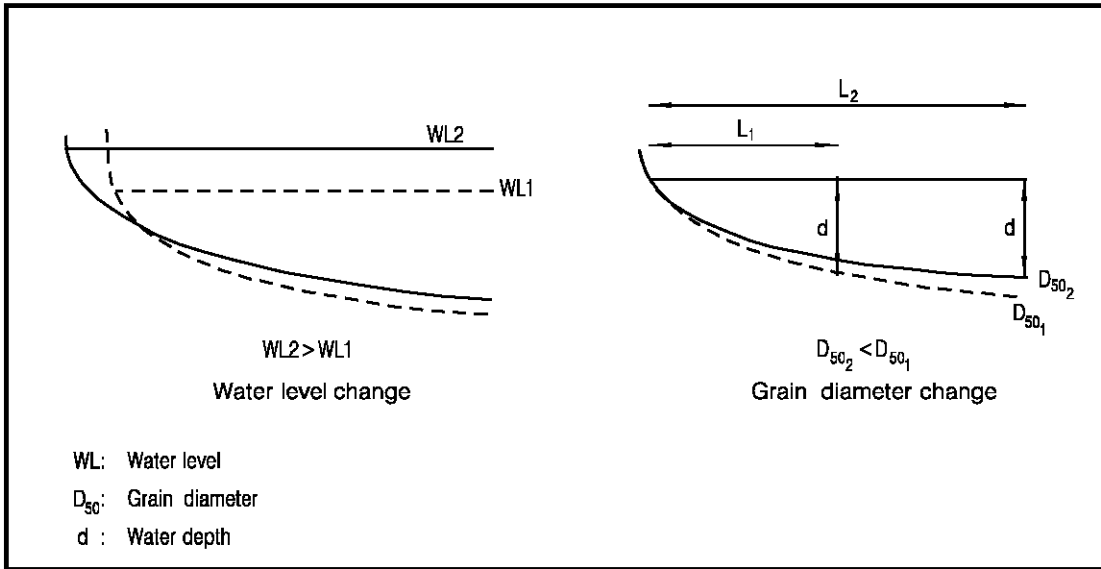

Figure 5 – Variation of Equilibrium Beach Profiles

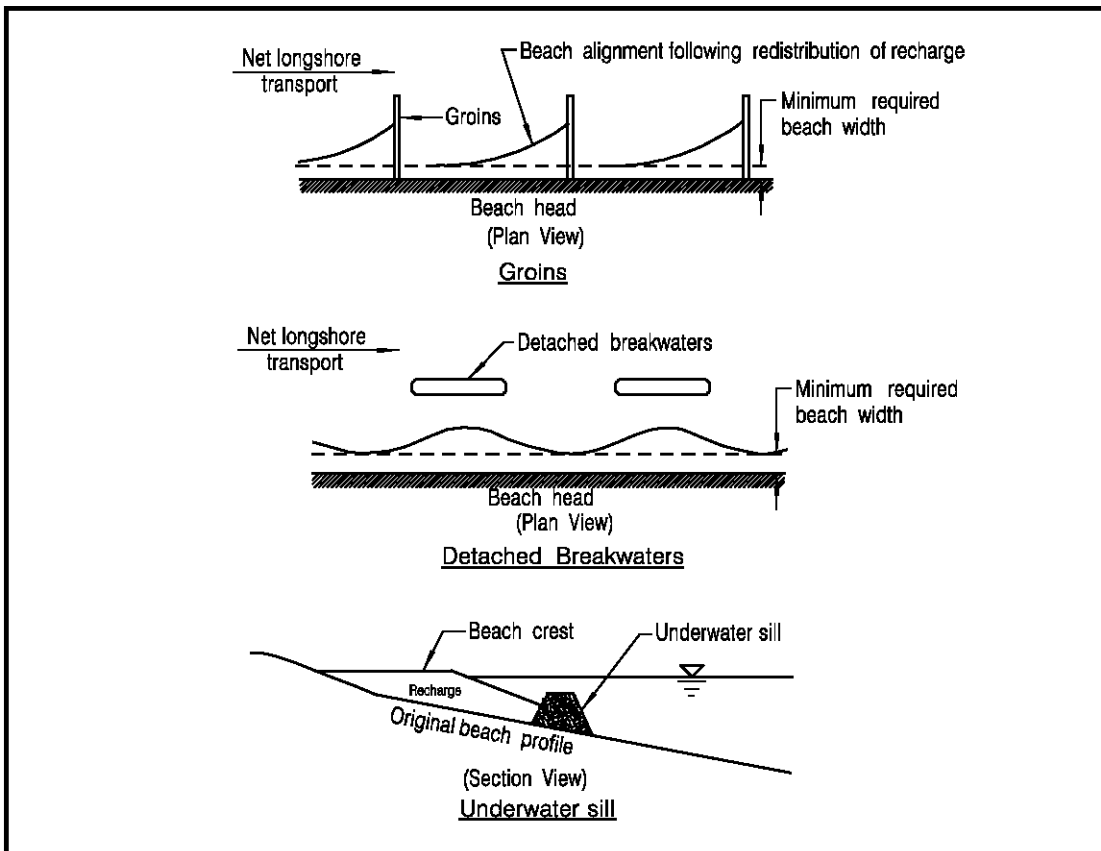

Figure 6 – Beach Protection Measures

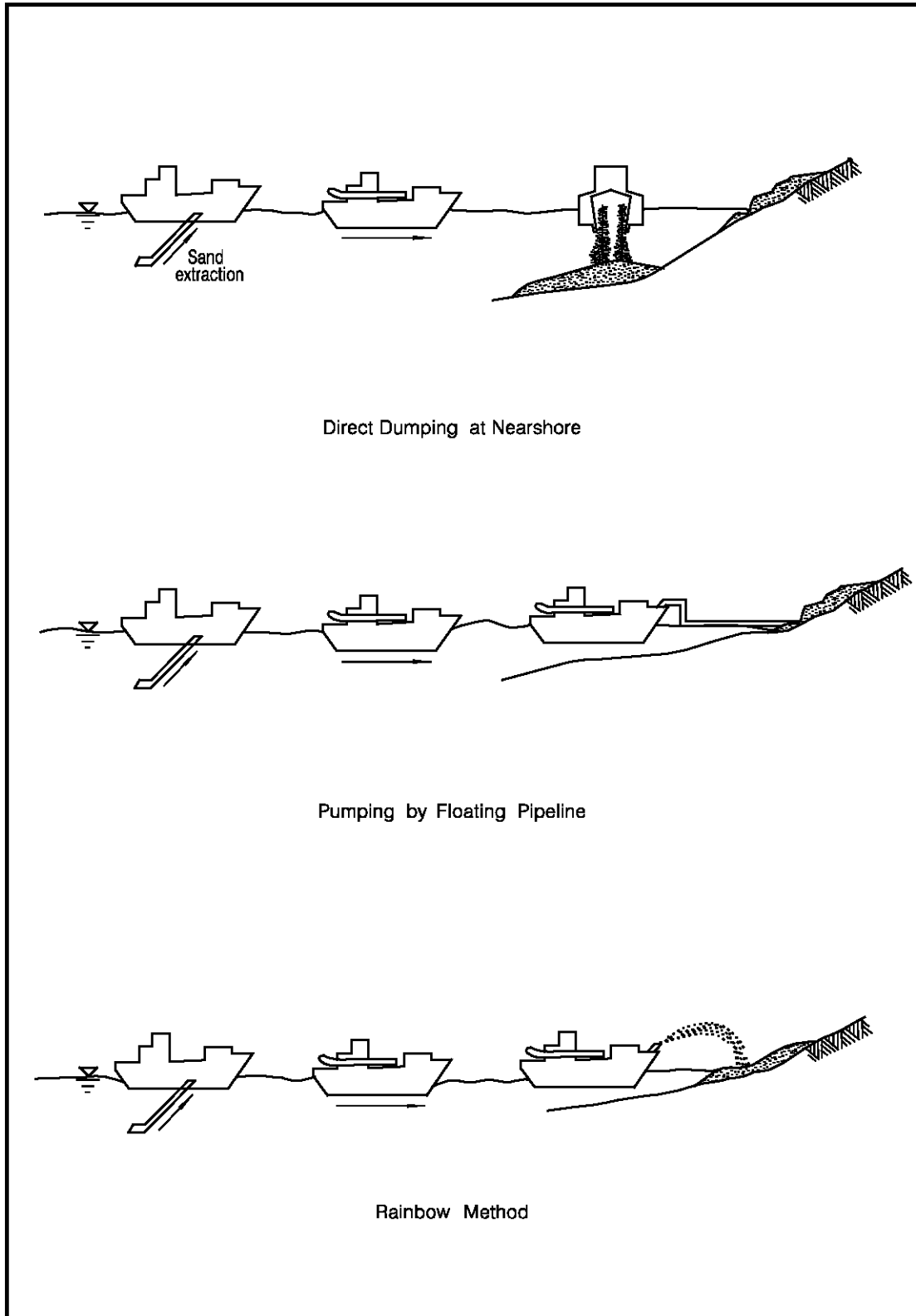

Figure 7 – Sand Placement Methods

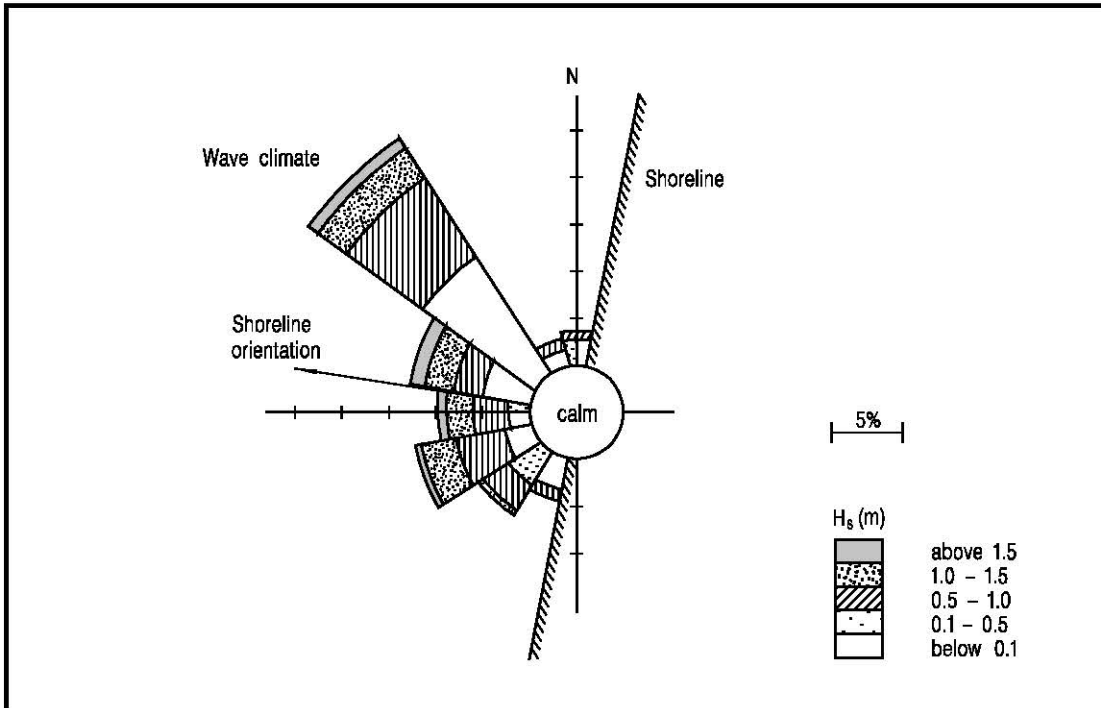

Figure 8 - Wave Rose

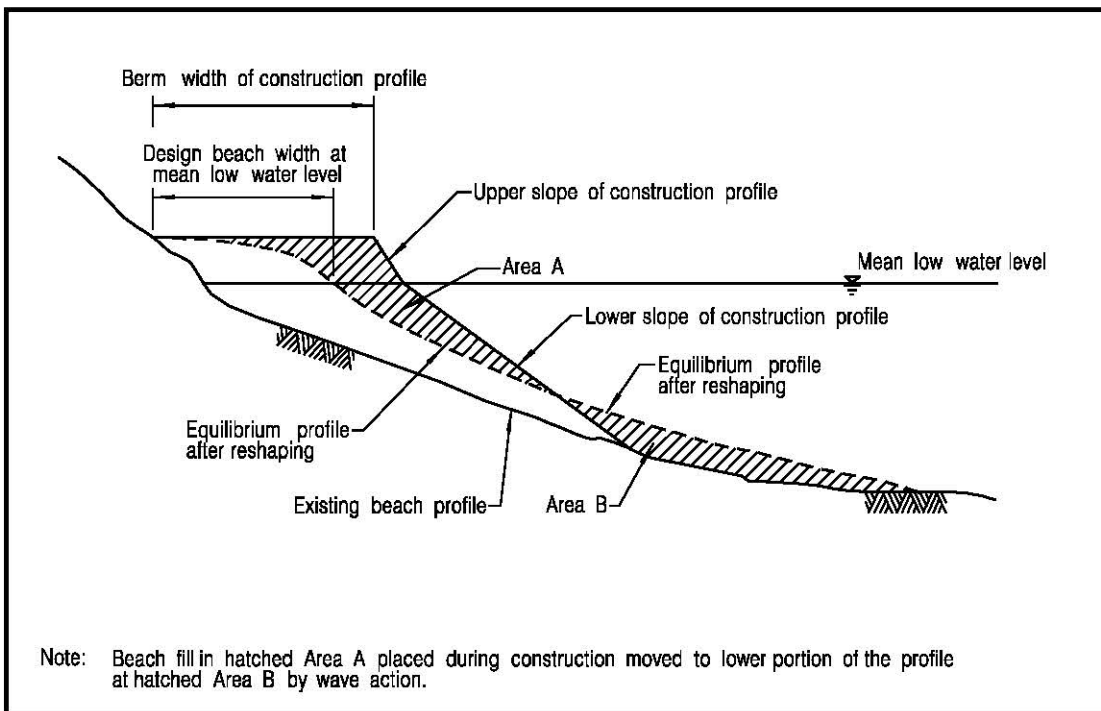

Figure 9 - Construction Profile

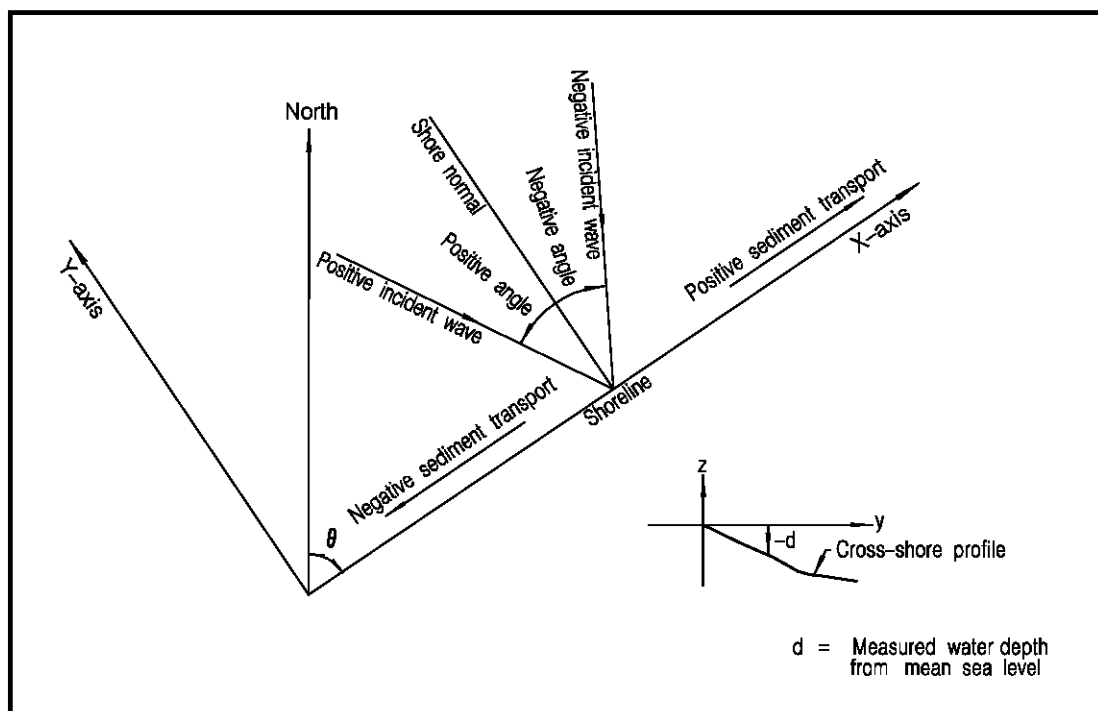

Figure 10 – Coordinate System for Longshore Transport Computation

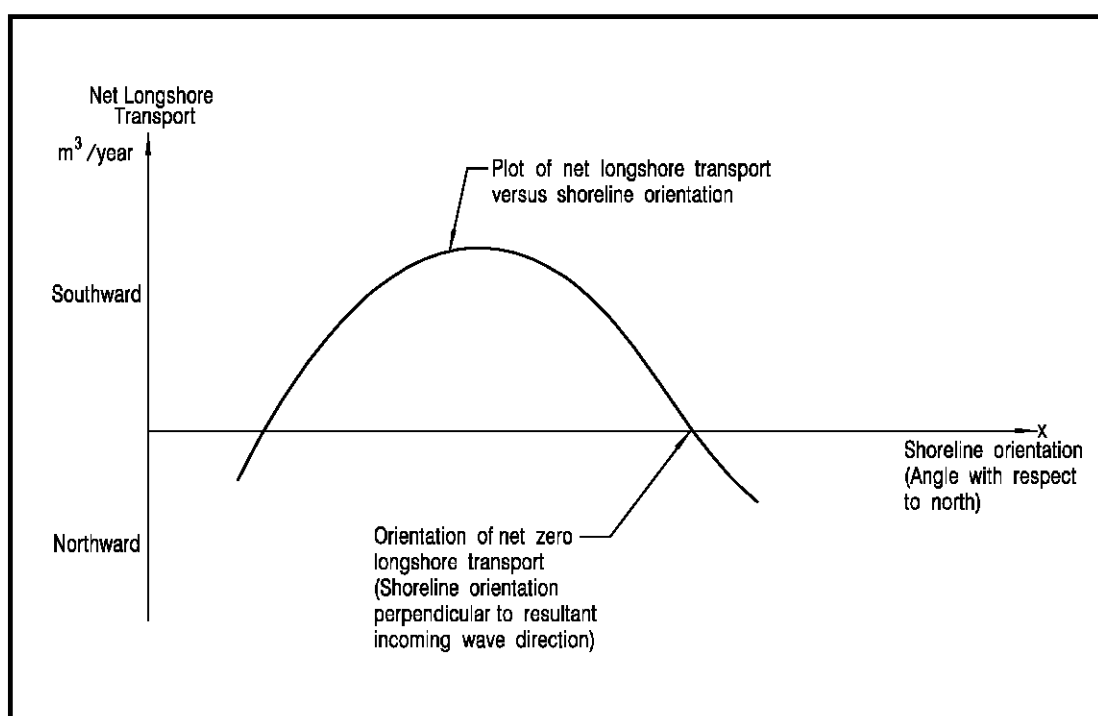

Figure 11 – Variation of Net Longshore Transport with Shoreline Orientation

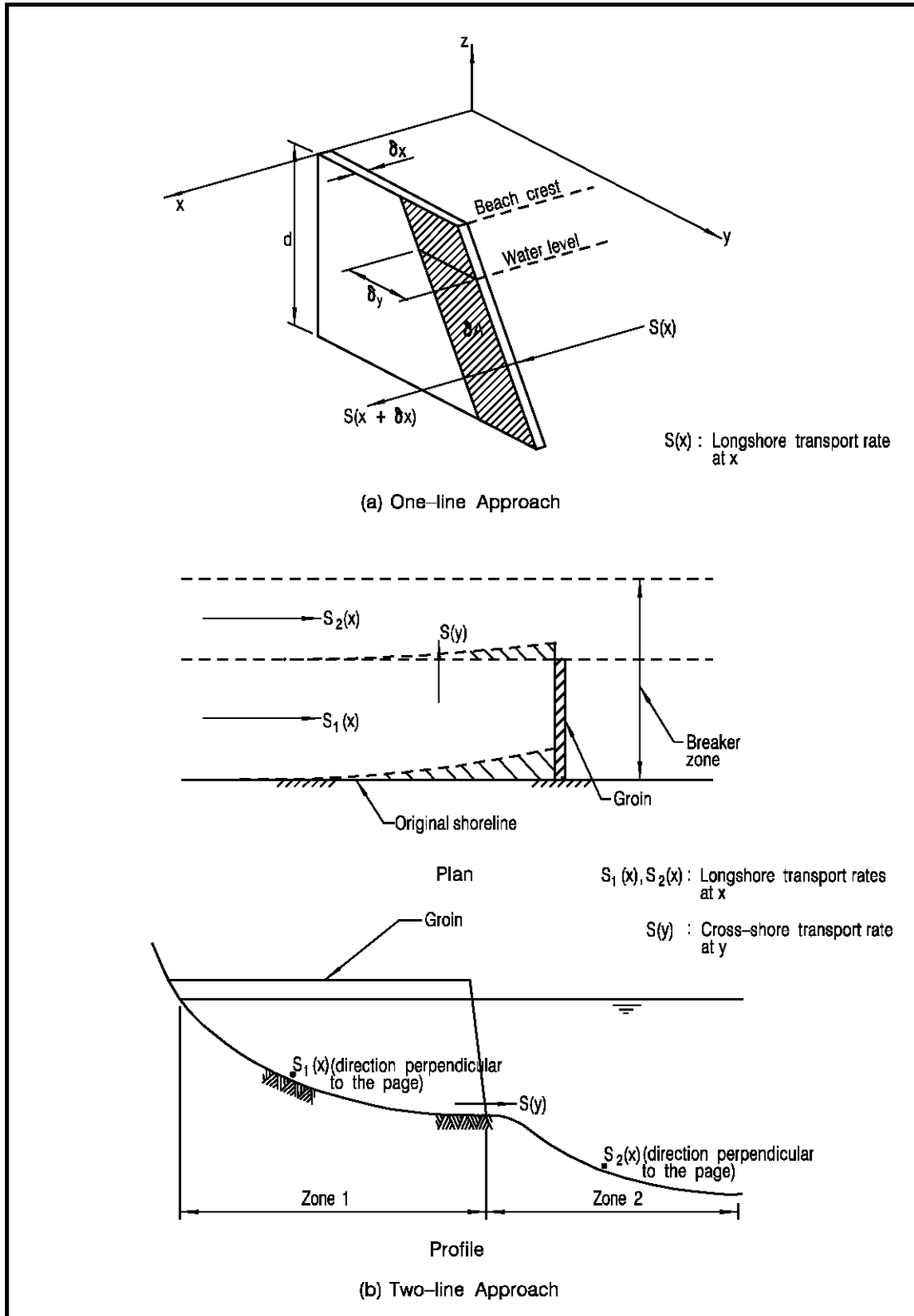

Figure 12 – One-line Approach and Multi-line Approach

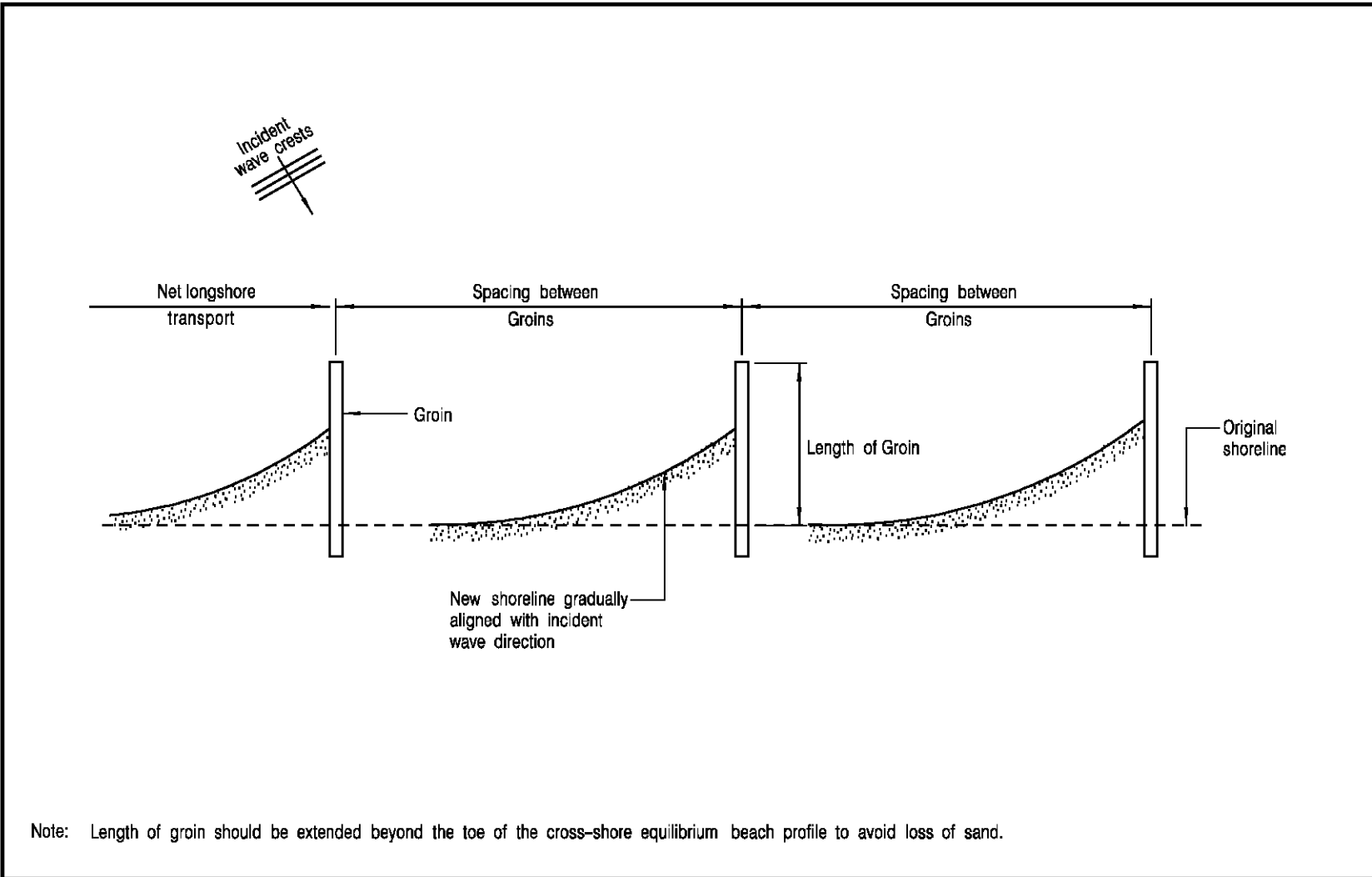

Figure 13 – Groins

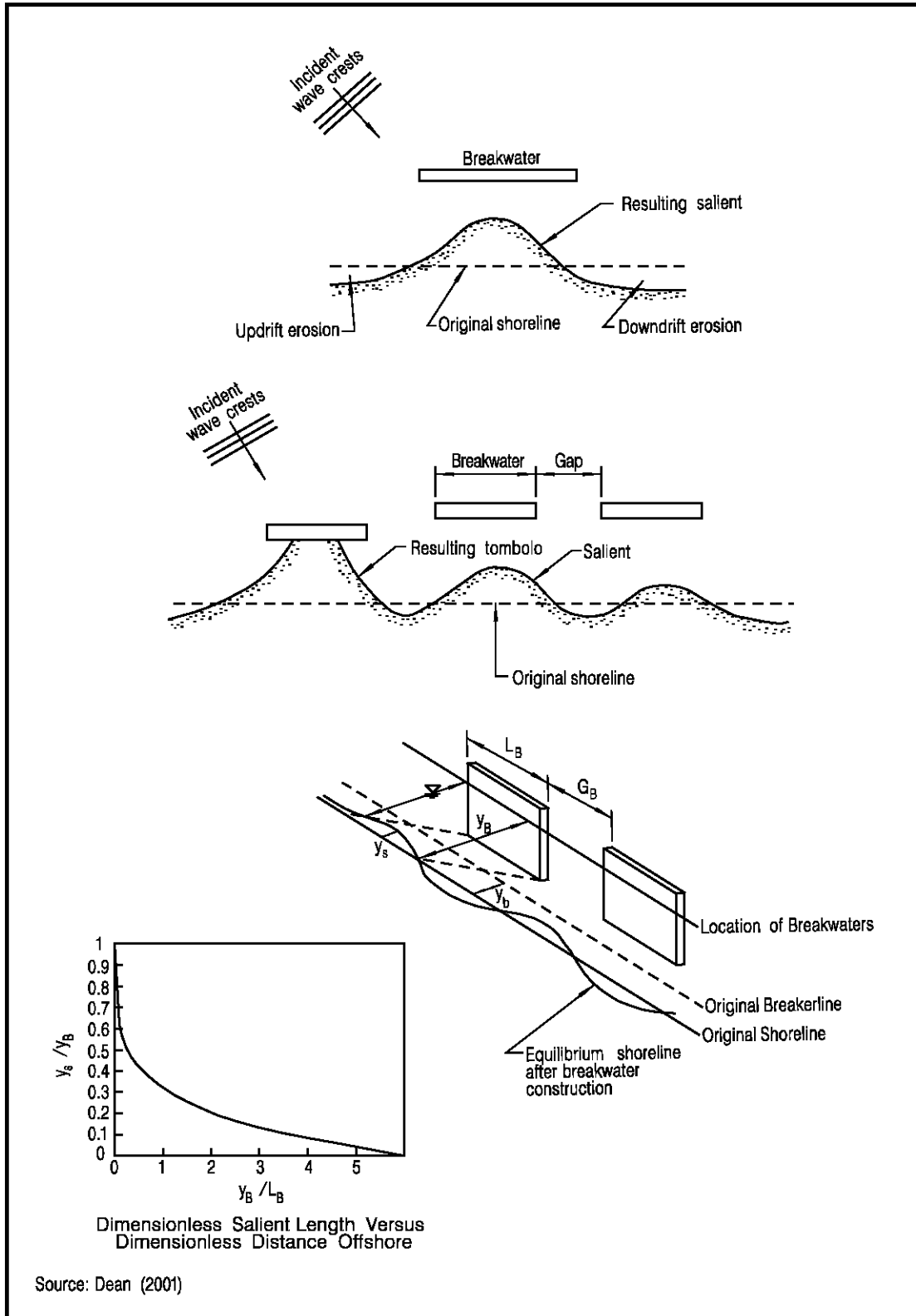

Figure 14 – Detached Breakwaters

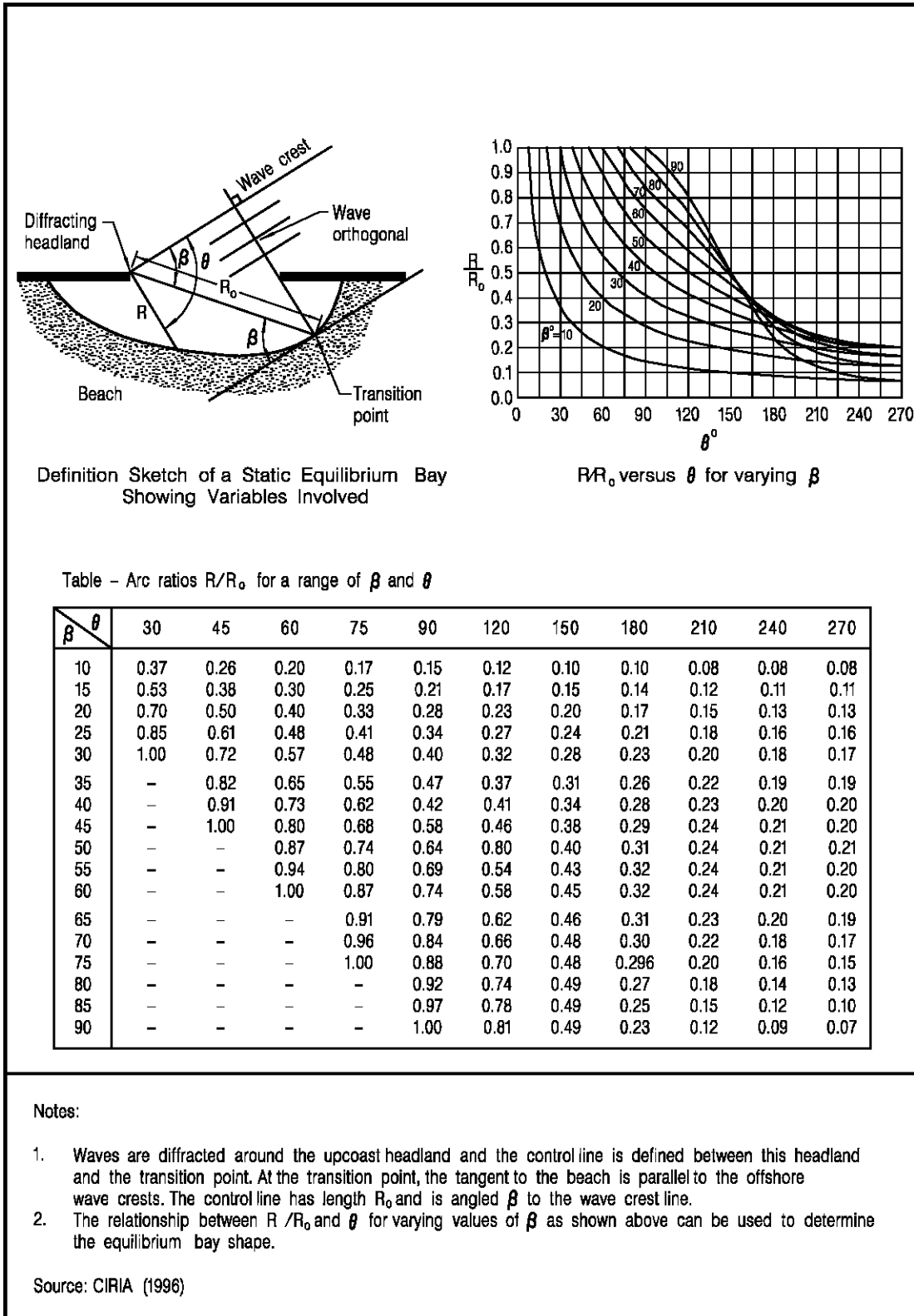

Figure 15 – Artificial Headlands

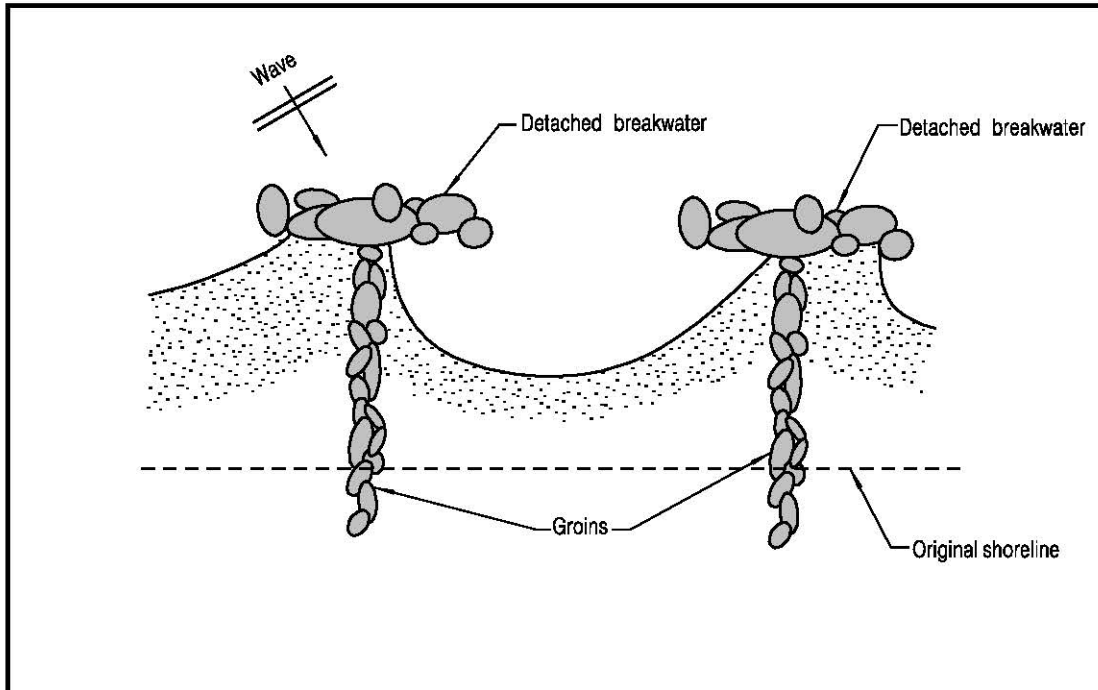

Figure 16 – Formation of Artificial Headlands by Groins and Detached Breakwaters

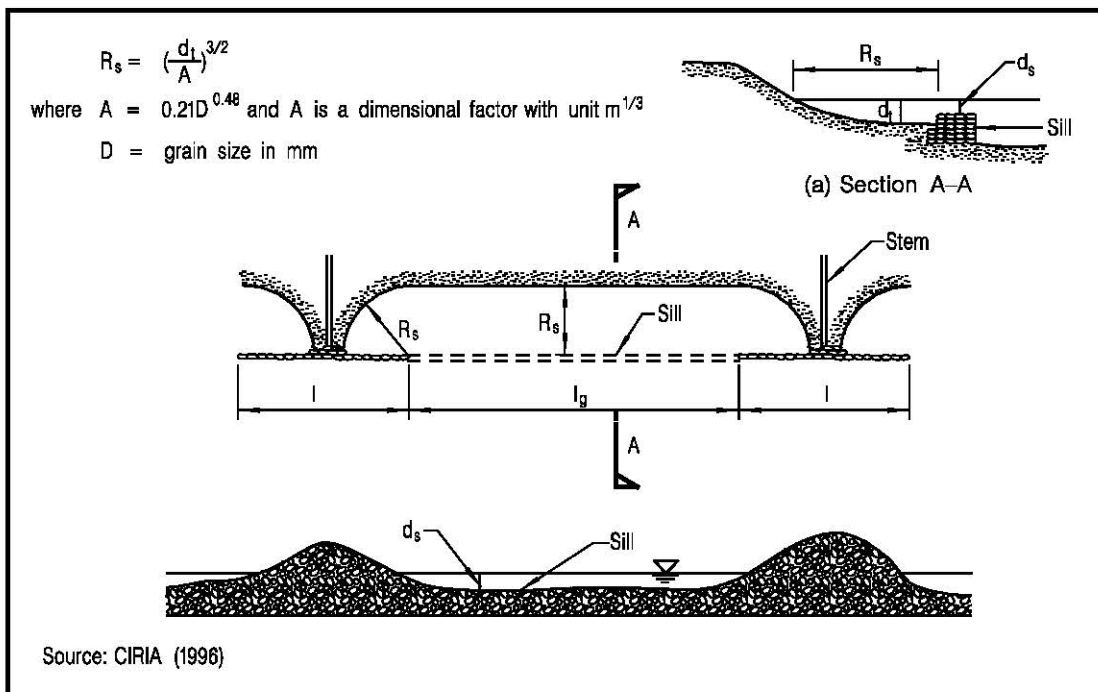

Figure 17 – Configuration of Underwater Sill and Associated Sand Beach of Relatively Mild Slope

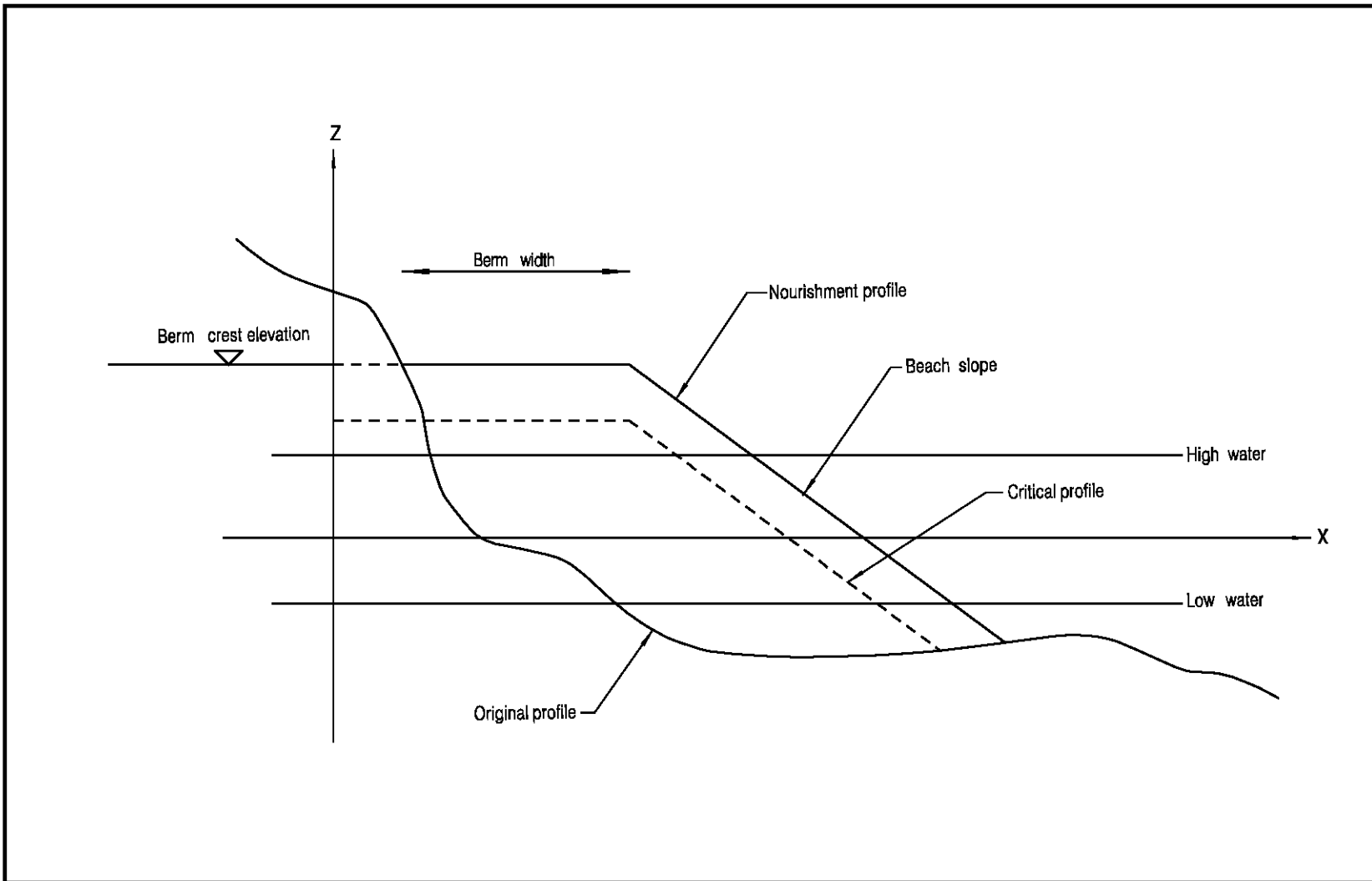

Figure 18 – Monitoring of Beach Profiles

APPENDIX A

FILL QUANTITY ESTIMATION

CONTENTS

	Page No.
TITLE PAGE	71
CONTENTS	73
A.1 GENERAL	75
A.2 EQUILIBRIUM PROFILE METHOD	75
A.3 EQUILIBRIUM SLOPE METHOD	77
A.4 OVERFILL RATIO METHODS	78
A.4.1 Krumbein and James Method	78
A.4.2 Dean Method	79
A.5 REFERENCES	80
LIST OF FIGURES	81

APPENDIX A FILL QUANTITY ESTIMATION

A.1 GENERAL

This Appendix describes the methods of estimating the fill quantity in beach nourishment. Designers may use all these methods to assess the potential range of required fill volume, and should not infer that coarser materials will necessarily last longer than native material when adopting these methods. For more details, reference should be made to CIRIA (1996).

A.2 EQUILIBRIUM PROFILE METHOD

The Dean's equilibrium method (Dean, 1991) determines the volume of recharged sand of a given grain size to increase the width of dry beach by a given amount. Dean proposed that beach profiles develop a characteristic parabolic equilibrium profile given by :

$$d = Ax^{2/3} \quad (A1)$$

where d is the depth below still water for any given horizontal distance, x , from the shoreline, both measured in metres.

A can be expressed as :

$$A = 0.21 D^{0.48} \quad (A2)$$

where D is the grain size (mm).

Three different types of profile depending on the relative values of A for the native sand and fill material are shown in Figure A1. The intersecting profile intersects the native profile before the closure depth d_{oc} . The non-intersecting profile, steeper than the native profile, does not intersect before the closure depth. For the sub-merged profile, the fill material is finer than the native material and insufficient volume has been added to increase the dry beach width.

The procedure of determining the fill volume is given as follows :

- (1) Determine the closure depth d_{oc} as :

$$d_{oc} = 1.75 H_s \quad (A3)$$

where H_s corresponds to the significant wave height being exceeded only 12 hours per year.

- (2) Select a berm crest height R_c and required increase in dry beach width Y .
- (3) Determine A_R and A_N from Equation A2 for the fill and native material respectively.
- (4) Determine whether the profiles are intersecting or non-intersecting using Equation A4 :

$$Y \left(\frac{A_N}{d_{oc}} \right)^{3/2} + \left(\frac{A_N}{A_R} \right)^{3/2} < 1 \quad \text{intersecting profile} \quad (A4)$$

$$Y \left(\frac{A_N}{d_{oc}} \right)^{3/2} + \left(\frac{A_N}{A_R} \right)^{3/2} > 1 \quad \text{non-intersecting profile}$$

- (5) Calculate the volume of fill V required per metre run of the beach to advance the shoreline by a distance Y :

If the profiles are intersecting, V is given by :

$$V = R_c Y + \frac{A_N Y^{5/3}}{\left[1 - \left(\frac{A_N}{A_R} \right)^{3/2} \right]^{2/3}} \quad (A5)$$

If the profiles are non-intersecting, V is given by :

$$V = R_c Y + \frac{3}{5} d_{oc}^{5/2} \left\{ \left[\frac{Y}{d_{oc}^{3/2}} + \left(\frac{1}{A_R} \right)^{3/2} \right]^{5/3} A_N - \left(\frac{1}{A_R} \right)^{3/2} \right\} \quad (A6)$$

A.3 EQUILIBRIUM SLOPE METHOD

The equilibrium slope method by Pilarczyk, van Overeem and Bakker (1986) bases the recharged profile on the present native profile. However, if the grain size of the fill material is different from the native material, the profile steepness is altered according to the following relationship :

$$l_R = \left(\frac{w_N}{w_R} \right)^{0.56} l_N \quad (\text{A7})$$

where w = fall velocity.

l = distance offshore of a given depth contour.

N = subscript to denote native material.

R = subscript to denote fill or recharge material.

For common beach sand of diameter D between 0.15 mm and 0.85 mm, the following approximation for fall velocity w may be used (in cm/s) :

$$w = 14D^{1.1} \quad (\text{A8})$$

where D is in mm.

If the fill material is coarser than the native material (i.e. $w_R > w_N$), the profile of the nourished beach will be steeper than the original profile as shown in Figure A2. The opposite effect applies to fill material finer than native material.

The above profile is used down to a cutoff depth d_c of the active beach defined by :

$$d_c = 1.75 H_s \quad (\text{A9})$$

where H_s is the nearshore significant wave height.

Beyond the cutoff depth d_c , the nourished beach thickness is assumed to decrease linearly within a transition zone until it intersects the original profile at an intersection depth d_i , given by $d_i \sim 3H_s$ as shown in Figure A2.

A.4 OVERFILL RATIO METHODS

A.4.1 Krumbein and James Method

Krumbein and James (1965) established a method for estimating the additional quantity of fill material required if the fill and native sediment are dissimilar. The method involved multiplying the required volume of beach material, assuming a natural grading, by a critical overfill ratio R_{crit} to determine the quantity of fill material over and above that required by the absolute dimensions of the proposed nourishment works. R_{crit} is given by :

$$R_{crit} = \frac{\sigma_{\phi R}}{\sigma_{\phi N}} \exp \left[- \frac{(M_{\phi N} - M_{\phi R})^2}{2(\sigma_{\phi N}^2 - \sigma_{\phi R}^2)} \right] \quad (A10)$$

where $\phi = -\log_2 D$ (D = mean sediment diameter in mm).

$M_\phi = (\phi_{84} + \phi_{16}) / 2$, larger values of M denote finer material.

$\sigma_\phi = (\phi_{84} - \phi_{16}) / 2$.

ϕ_{84} = the particle size in phi unit that is exceeded by 84% (by dry weight) of the total sample.

ϕ_{16} = the particle size in phi unit that is exceeded by 16% (by dry weight) of the total sample.

R = Subscript to denote fill or recharge material.

N = Subscript to denote native material.

The overfill ratio R_{crit} determined by the Krumbein and James Method cannot be applied to all the possible combinations of fill and native sediment grading, which are summarized as follows :

- (1) Fill material finer than native material $M_{\phi R} > M_{\phi N}$

If the fill material is more poorly sorted than the native material ($\sigma_{\phi R} > \sigma_{\phi N}$), the best estimate of the required overfill will be given by R_{crit} .

- (2) Fill material coarser than native material $M_{\phi R} < M_{\phi N}$

If the fill material is more poorly sorted than the native material ($\sigma_{\phi R} > \sigma_{\phi N}$), the required overfill ratio may probably be less than R_{crit} .

- (3) Fill material finer than native material $M_{\phi R} > M_{\phi N}$

If the fill material is better sorted than the native material ($\sigma_{\phi R} < \sigma_{\phi N}$), the distributions cannot be matched. Loss of fill cannot be predicted and will probably be large.

- (4) Fill material coarser than native material $M_{\phi R} < M_{\phi N}$

If the fill material is better sorted than the native material ($\sigma_{\phi R} < \sigma_{\phi N}$), the distributions cannot be matched but the fill material should be stable. Scour of native material fronting toe of fill may be induced.

A.4.2 Dean Method

The Krumbein and James Method is only applicable if the native material is better sorted than the fill material. If the fill material is better sorted than the native material, this method simply does not apply. Secondly, the Krumbein and James Method assumes that the portion of the fill material retained on the beach after sorting by waves and current will have exactly the same size distribution of the native material. This implies that both the fine and coarse portion of the fill will be lost. This feature is not consistent with the knowledge of sediment transport process as the coarser portion of the fill will likely remain on the beach without being carried away by waves and currents (Dean, 1974; also Dean and Dalrymple, 2002). The overfill ratio by the Krumbein and James Method will tend to be overestimated.

Dean (1974) addressed the above shortcomings by assuming that only the finer portion of the fill will be winnowed away by prevailing wave condition leaving the mean diameter of altered distribution of fill material to be at least as large as the mean diameter of native material. Dean defines the overfill ratio as the required replacement volume of fill material to obtain one unit of compatible beach material and uses the 'phi' unit to describe the size of sand particle, given by :

$$\text{Size in phi unit} = -\log_2 D \quad (\text{A11})$$

If the mean diameter in phi unit and the standard deviation in phi unit of both native and fill material are known, the overfill ratio can be determined from Figure A3.

A.5 REFERENCES

- CIRIA (1996). Report 153 – Beach Management Manual. Construction Industry Research and Information Association, United Kingdom, 448p.
- Dean, R.G. (1974). Compatibility of Borrow Material for Beach Fills. Proceedings of the 14th International Conference on Coastal Engineering, ASCE, Copenhagen, pp. 1319-1333.
- Dean, R.G. (1991). Equilibrium beach profiles : Characteristics and applications. Journal of Coastal Research, Volume 7, No. 1, pp. 53-84.
- Dean, R.G. and R.A. Dalrymple (2002). Coastal Processes with Engineering Applications. Cambridge University Press, 475p.
- Krumbein, W.C. and James, W.R. (1965). A log-normal size distribution model for estimating stability of beach fill material. Technical Memorandum No. 16, Coastal Research Centre, US Army Corps of Engineers.
- Pilarczyk, K.W., Van Overeem, J. and Bakker, W.T. (1986). Design of beach nourishment scheme. Proceedings 20th International Conference on Coastal Engineering, Taiwan.

LIST OF FIGURES

Figure No.		Page No.
A1	Generic Types of Recharged Profiles	83
A2	Profile of Beach Fill	84
A3	Required Replacement Volume K of “Borrow” Material to Obtain One Unit of “Compatible” Beach Material	85

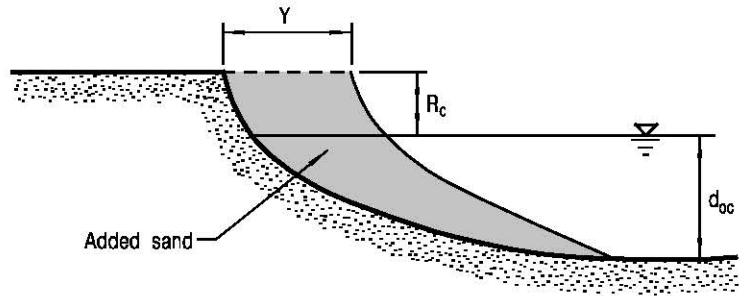

a) Intersecting Profile;
Recharge Grain Size, $D_R >$ Native Grain Size, D_N ($A_R > A_N$)

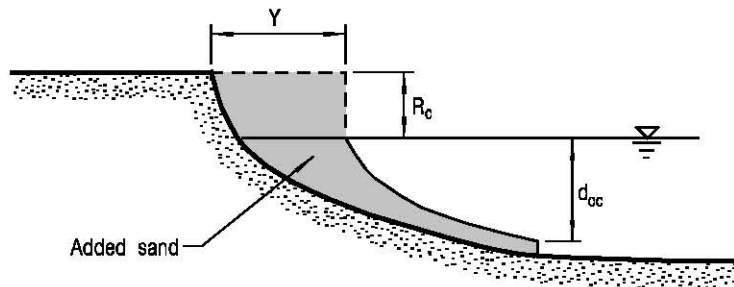

b) Non-intersecting Profile;
Recharge Grain Size, $D_R <$ Native Grain Size, D_N ($A_R < A_N$)

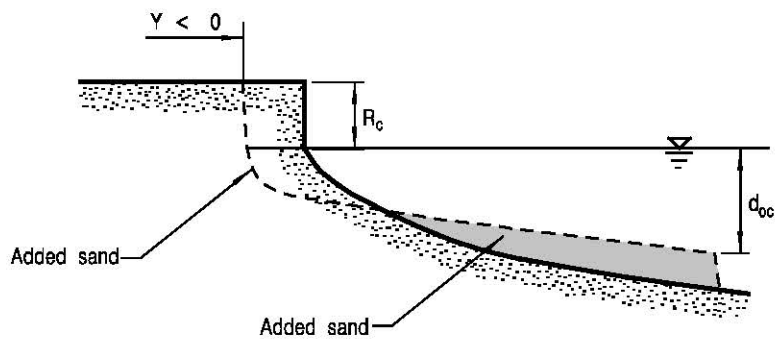

c) Submerged Profile;
Recharge Grain Size, $D_R <$ Native Grain Size, D_N ($A_R < A_N$)

Figure A1 – Generic Types of Recharged Profiles

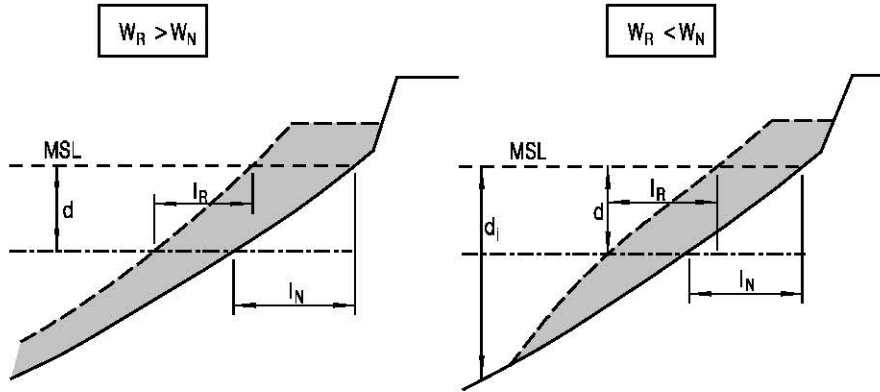

Effect of Grain Size on Profile Steepness

Note:

1. w = fall velocity
- l = distance offshore of a given depth contour
- subscript N = denotes native material
- subscript R = denotes recharge material

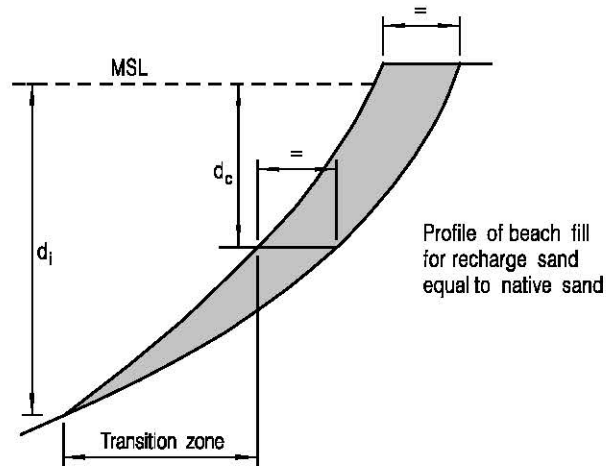

Notes:

1. H_s corresponds to nearshore wave conditions
2. $d_i \approx 3H_s$
3. $d_c = 1.75 H_s$

Source: CIRIA (1996)

Figure A2 – Profile of Beach fill

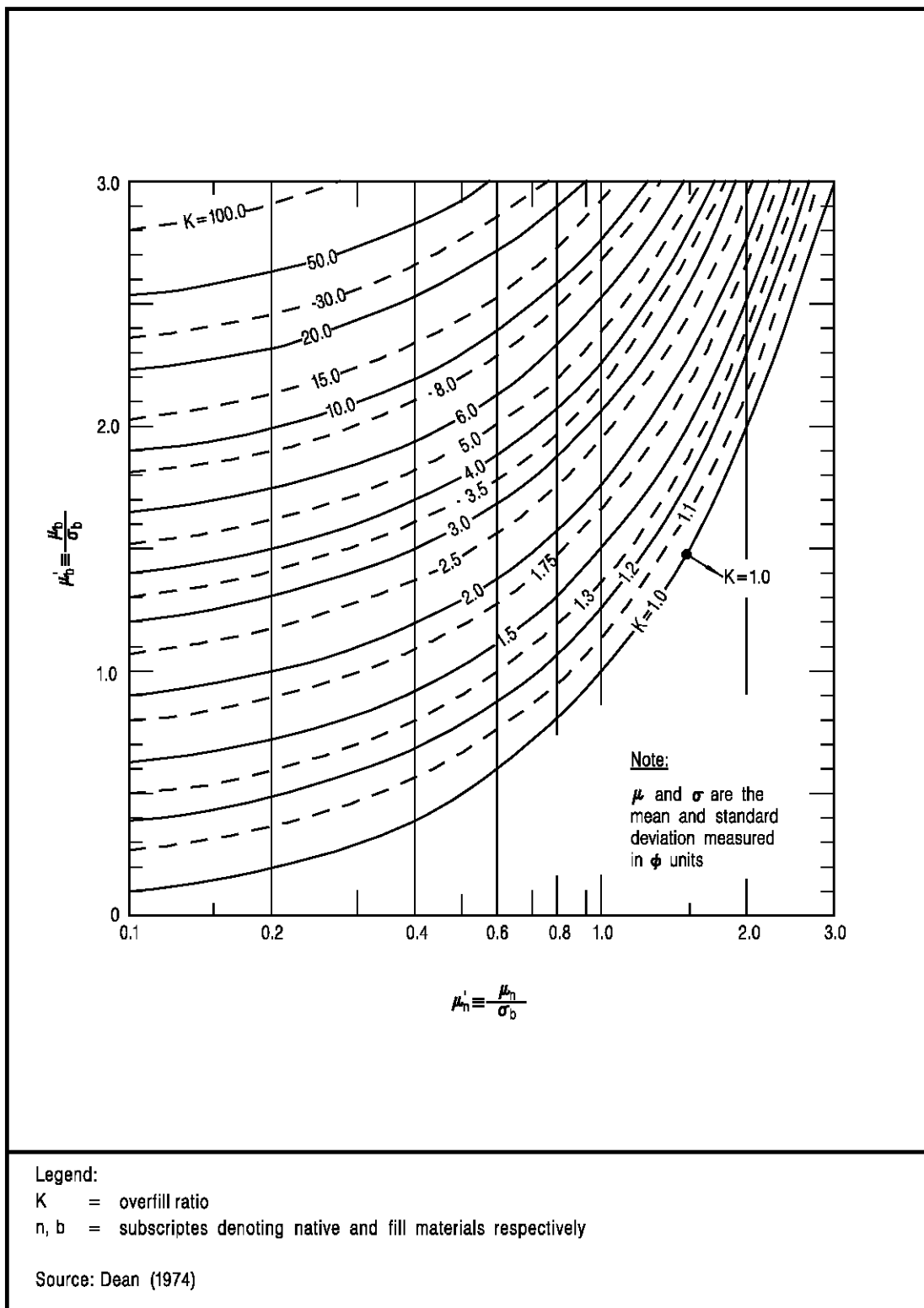

Figure A3 – Required Replacement Volume, K, of "Borrow" Material to Obtain One Unit of "Compatible" Beach Material

APPENDIX B

WORKED EXAMPLES

CONTENTS

	Page No.
TITLE PAGE	87
CONTENTS	89
B.1 FILL QUANTITY	91
B.2 CONSTRUCTION PROFILE AND EQUILIBRIUM PROFILE	96
B.3 NET LONGSHORE TRANSPORT	98
B.4 EQUILIBRIUM SHORELINE ORIENTATION	102
B.5 EQUILIBRIUM PLAN FORM	104

B.1 FILL QUANTITY

Reference Section 5.2.

Given

Significant wave height $H_s = 2.0$ m

D_{50} of native sand = 0.3 mm

D_{50} of recharged sand = 0.5 mm

Mean sea level MSL = +1.3 mPD

Crest level = +3.0 mPD

Required beach width at mean sea level $Y = 30.0$ m

Find

Estimate the fill quantity.

Solution

(1) Equilibrium Profile Method

$$R_c = 3.0 - 1.3 = 1.7 \text{ m}$$

$$d_{oc} = 1.75 H_s = 1.75 (2.0) = 3.5 \text{ m}$$

$$A_N = 0.21 D^{0.48} = 0.21 (0.3)^{0.48} = 0.1178$$

$$A_R = 0.21 D^{0.48} = 0.21 (0.5)^{0.48} = 0.1506$$

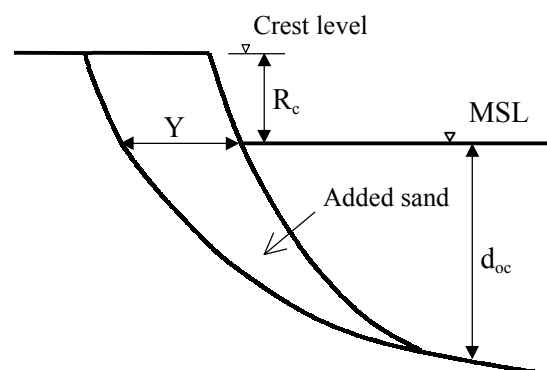

(Note : Subscripts N and R denote native sand and recharge sand respectively.)

$$\begin{aligned} & Y \left(\frac{A_N}{d_{oc}} \right)^{3/2} + \left(\frac{A_R}{A_N} \right)^{3/2} \\ &= (30.0) \left(\frac{0.1178}{3.5} \right)^{3/2} + \left(\frac{0.1178}{0.1506} \right)^{3/2} \\ &= 0.877 < 1 \end{aligned}$$

Therefore, the profile is intersecting.

The volume of fill required

$$\begin{aligned}
 &= R_c Y + \frac{A_N Y^{5/3}}{\left[1 - \left(\frac{A_N}{A_R}\right)^{3/2}\right]^{2/3}} \\
 &= (1.7)(30.0) + \frac{(0.1178)(30.0)^{5/3}}{\left[1 - \left(\frac{0.1178}{0.1506}\right)^{3/2}\right]^{2/3}} \\
 &= 125.8 \text{ m}^3/\text{m}
 \end{aligned}$$

(2) Equilibrium Slope Method

The recharged profile is governed by the following equation :

$$w_N = 14D^{1.1} = 14(0.3)^{1.1} = 3.724 \text{ cm/s}$$

$$w_R = 14D^{1.1} = 14(0.5)^{1.1} = 6.531 \text{ cm/s}$$

$$l_R = \left(\frac{w_N}{w_R}\right)^{0.56} l_N = \left(\frac{3.724}{6.531}\right)^{0.56} l_N = 0.7301 l_N$$

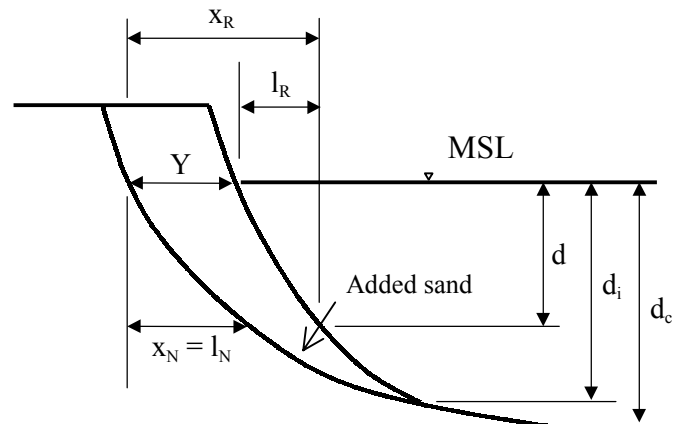

The existing beach profile is obtained from sounding survey results, or may be approximated by the following equation :

$$\begin{aligned}
 d &= A_N x_N^{2/3} \\
 &= 0.21 D^{0.48} x_N^{2/3} \\
 &= 0.21 (0.3)^{0.48} x_N^{2/3} \\
 &= 0.1178 x_N^{2/3}
 \end{aligned}$$

$$\text{or } x_N = \left(\frac{d}{0.1178}\right)^{3/2}$$

where d is the depth below still water level for any given horizontal distance x_N measured from the existing shoreline, both measured in metres.

$$\text{Cutoff depth } d_c = 1.75 H_s = 1.75 (2.0) = 3.5 \text{ m}$$

$$\text{Intersection depth } d_i = 3 H_s = 3 (2.0) = 6.0 \text{ m}$$

The equilibrium profile, down to a cutoff depth d_c , may be approximated by the following equation :

$$l_R = 0.7301 l_N$$

$$x_R - Y = 0.7301 x_N$$

$$x_R - 30.0 = 0.7301 \left(\frac{d}{0.1178} \right)^{3/2}$$

$$d = 0.1178 \left(\frac{x_R - 30.0}{0.7301} \right)^{2/3}$$

$$d = 0.1453 (x_R - 30.0)^{2/3}$$

$$\text{or } x_R = \left(\frac{d}{0.1453} \right)^{3/2} + 30.0$$

$$\text{At cutoff depth } d_c, \quad x_R = 148.2 \text{ m}$$

$$x_N = 162.0 \text{ m}$$

Since $x_N > x_R$, the recharged beach profile intersects the existing beach profile before the cutoff depth.

The volume of fill required is estimated from the shaded area in the figure below :

$$= A1 + A2$$

$$= 30.0 \times 1.7 + 47.6$$

$$= 98.6 \text{ m}^3/\text{m}$$

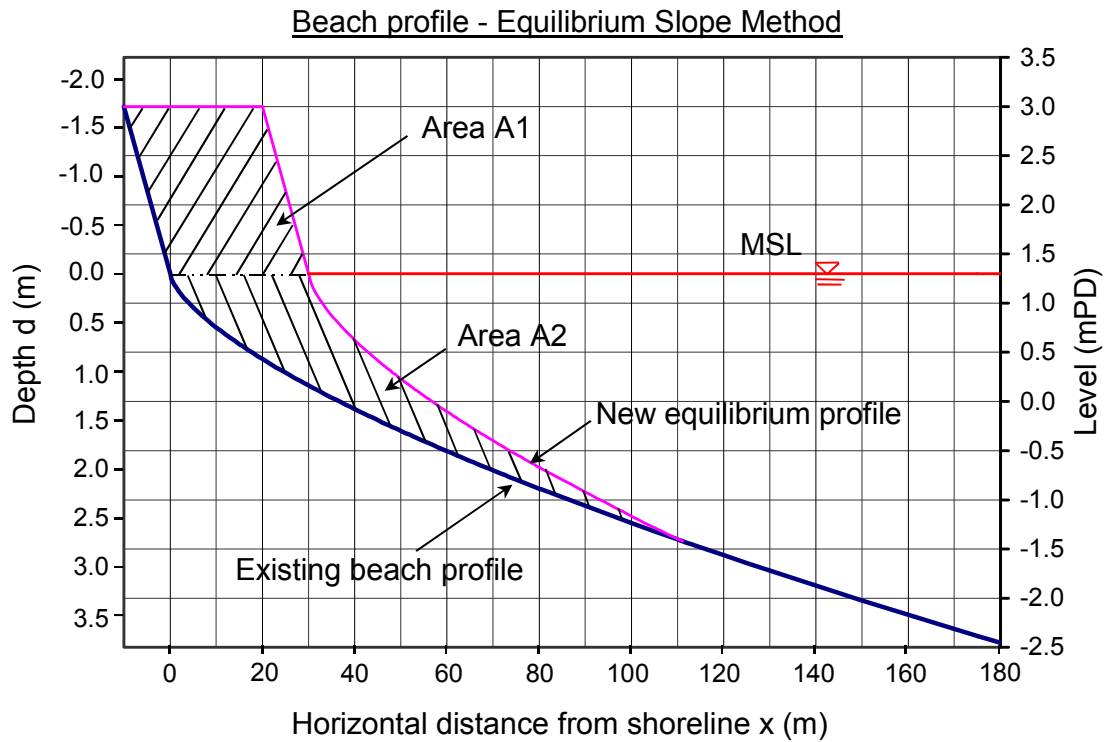

(3) Overfill Ratio

By Krumbein and James Method :

Given further that $\phi_{N_{84}} = -\log_2 0.2 = 2.32$

$$\phi_{N_{16}} = -\log_2 0.4 = 1.32$$

$$\phi_{R_{84}} = -\log_2 0.45 = 1.15$$

$$\phi_{R_{16}} = -\log_2 0.55 = 0.86$$

where $\phi_{N_{84}}$ and $\phi_{R_{84}}$ are the particle sizes that are exceeded by 84% by dry weight of the native and recharged sand samples respectively in phi unit. Similarly, $\phi_{N_{16}}$ and $\phi_{R_{16}}$ are the particle sizes that are exceeded by 16% by dry weight of the sand samples in phi unit.

Therefore,

$$M_{\phi N} = (\phi_{N_{84}} + \phi_{N_{16}}) / 2 = (2.32 + 1.32) / 2 = 1.82$$

$$M_{\phi R} = (\phi_{R_{84}} + \phi_{R_{16}}) / 2 = (1.15 + 0.86) / 2 = 1.01$$

$$\sigma_{\phi N} = (\phi_{N_{84}} - \phi_{N_{16}}) / 2 = (2.32 - 1.32) / 2 = 0.50$$

$$\sigma_{\phi R} = (\phi_{R_{84}} - \phi_{R_{16}}) / 2 = (1.15 - 0.86) / 2 = 0.15$$

$$\therefore M_{\phi R} < M_{\phi N} \ \& \ \sigma_{\phi R} < \sigma_{\phi N}$$

\Rightarrow The distribution cannot be matched but the fill should be stable. Scouring of native material fronting toe of fill may be induced. The overfill ratio is re-estimated by the Dean Method.

By Dean Method :

The standard deviation of the fill is found to be 0.05 mm, determined from sieve tests.

Size in phi unit = $-\log_2 D$

$$\mu'_n = \frac{\mu_n}{\sigma_b} = \frac{-\log_2 0.3}{-\log_2 0.05} = \frac{1.74}{4.32} = 0.40$$

$$\mu'_b = \frac{\mu_b}{\sigma_b} = \frac{-\log_2 0.5}{-\log_2 0.05} = \frac{1.00}{4.32} = 0.23$$

From Figure A3, the overfill ratio is equal to 1.

(4) Sand Quantity

The average of the fill volume estimated by the equilibrium profile method and the equilibrium slope method is $(125.8 + 98.6) / 2 = 112.2 \text{ m}^3/\text{m}$. Since the overfill ratio is 1, the sand quantity is therefore equal to $112.2 \text{ m}^3/\text{m}$.

It should be noted that loss of fill may occur due to actions of waves and currents during fill placement. The actual fill quantity required may be more than the above-calculated quantity.

B.2 CONSTRUCTION PROFILE AND EQUILIBRIUM PROFILE

Reference Sections 5.3 and 5.4.

Given further that

Mean low lower water level = +0.5 mPD

Extreme water level = +2.9 mPD

Find

Determine the construction profile based on the fill quantity computed in Example B.1 and re-estimate the equilibrium profile.

Solution

Estimated sand quantity = 112.2 m³/m from Example B.1.

Try a berm width of construction profile = 35 m and assume upper slope = 1:10, lower slope = 1:15 for $D_{50} = 0.3 \sim 0.5$ mm.

Based on the above information, the construction profile is plotted against the existing beach profile as shown in the following graph. From the graph, the re-calculated sand quantity is equal to 115 m³/m. Therefore, take this as the construction profile.

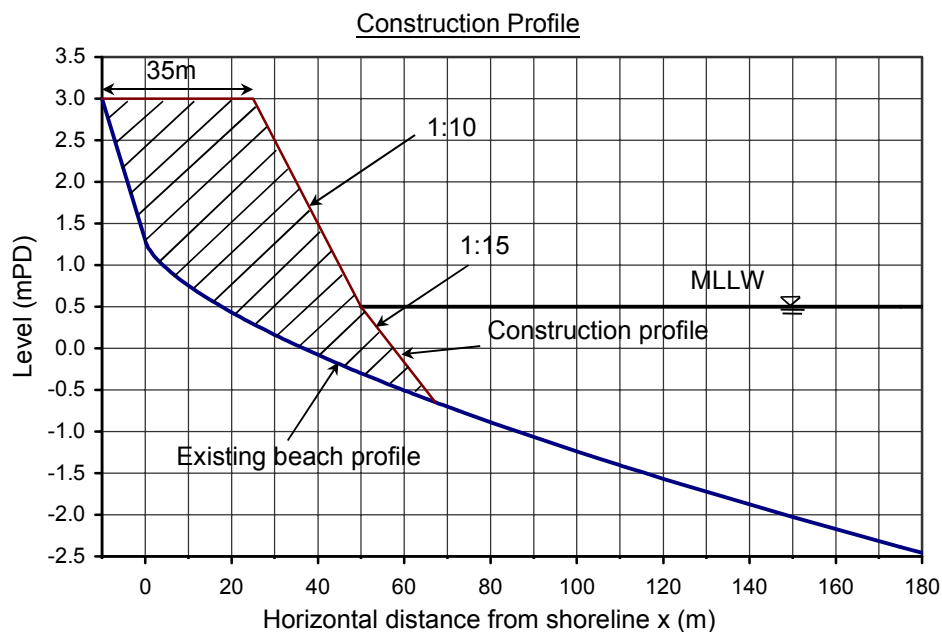

The equilibrium profile from empirical formulae in Example B.1 is an initial estimate for computing the sand quantity. A more precise, efficient estimate of the equilibrium profile can be carried out by means of cross-shore transport modelling, using the construction profile as a starting profile together with relevant extreme/normal wave conditions and water levels. Details of input requirements should be made to the user's manual of the modelling software. Diagrammatic sketch of the computation results is shown in the following graph.

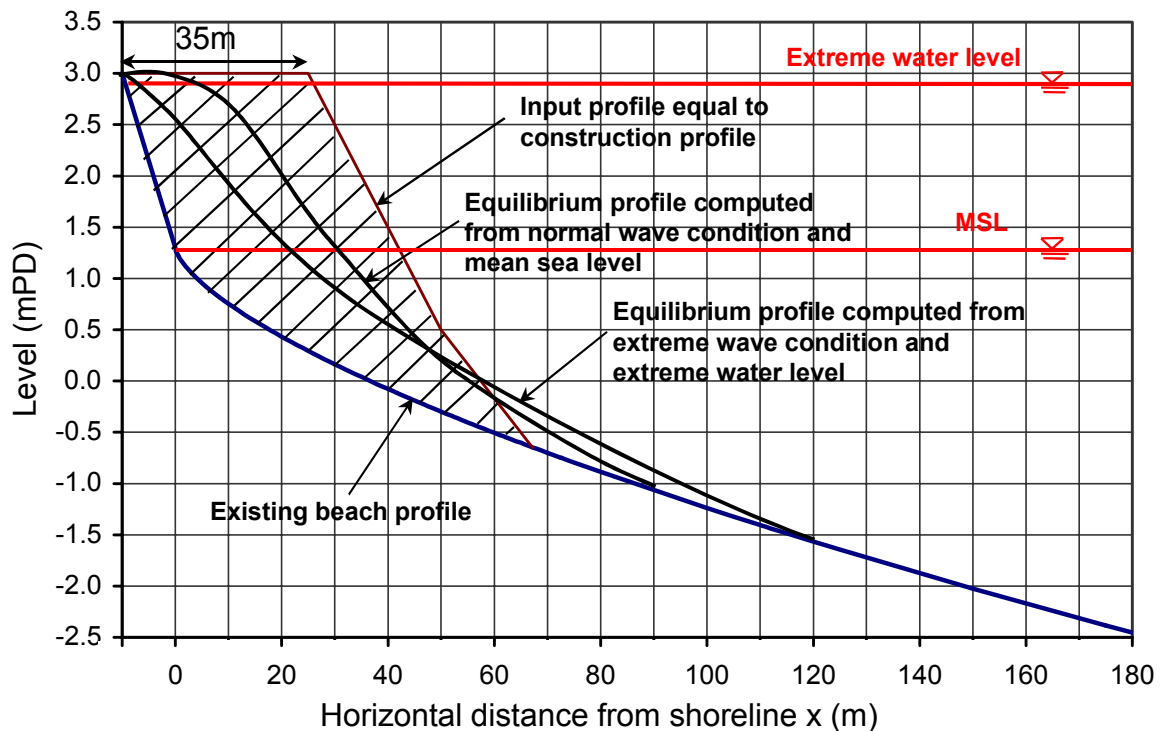

The above computed equilibrium profile under extreme condition may be used as input profile to re-compute the equilibrium profile under normal condition. Alternatively, the computed equilibrium profile under normal condition may be used as the input profile to re-compute the equilibrium profile under extreme condition. These steps have to be re-iterated to assess the final equilibrium profile of the beach.

B.3 NET LONGSHORE TRANSPORT

Reference Sections 5.5.1 and 5.5.2.

Given

The following table gives the fictitious wave height, period, incident angle and duration of occurrence at a shore running 56° from the North.

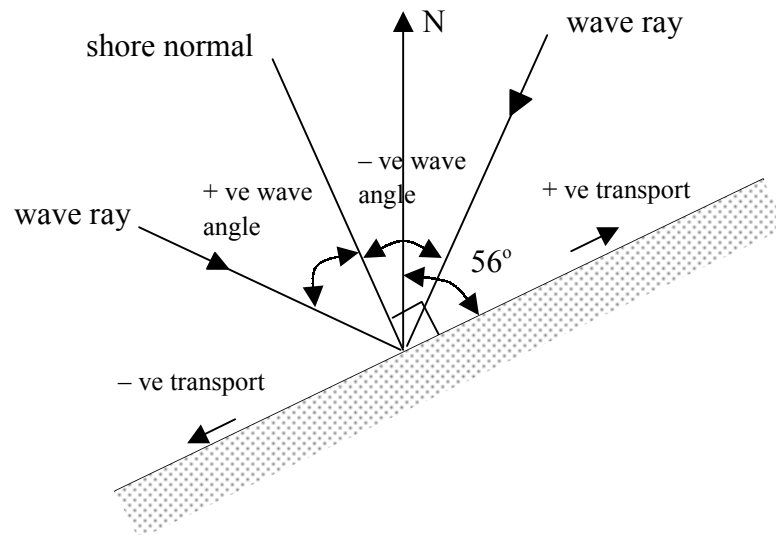

Wave height at breaker line H_b (m)	Yearly occurrence percentage (%)	Period T (s)	Incident wave bearing ($^\circ$)
calm (<0.06)	65.2	-	-
0.06	3.0	0.86	353.7
0.24	3.8	1.92	351.6
0.34	0.3	2.60	341.7
0.07	3.7	0.91	16.7
0.20	5.9	2.07	1.9
0.34	0.4	2.80	349.6
0.08	1.9	3.30	269.3
0.19	0.3	4.00	272.6
0.09	1.5	1.24	256.1
0.23	4.2	2.84	270.2
0.36	0.1	3.90	276.4
0.11	2.1	1.13	259.2
0.29	1.2	2.66	272.9
0.37	0.1	3.70	279.4
0.09	1.5	1.11	281.7
0.28	1.1	2.59	281.8
0.38	0.3	3.55	286.5
0.08	1.8	0.95	318.7
0.26	1.5	2.08	314.8
0.36	0.1	2.80	313.8
> 0.38	negligible	-	-

Find

Determine the net longshore transport rate and direction.

Solution

Using CERC longshore transport formula :

$$s_l = BH_b^2 c_b \sin(2\phi_b)$$

- where
- s_l = longshore transport due to breaking wave (m^3/s)
 - B = a constant equal to about 0.025
 - H_b = wave height at breaker line (m)
 - ϕ_b = breaker angle with respect to shore normal ($^\circ$)
 - c_b = wave velocity at breaker line (m/s)
 - = $\frac{L_b}{T}$
 - L_b = wavelength at breaking
 - = $\frac{gT^2}{2\pi} \tanh\left(\frac{2\pi d_b}{L_b}\right)$
 - d_b = depth at breaking
 - = $H_b/0.78$ (a simplified, approximate assumption)

Wave Condition i	H_b (m)	ϕ_b relative to shore normal (°)	T (s)	$d_b = \frac{H_b}{0.78}$ (m)	$L_b = \frac{gT^2}{2\pi} \tanh\left(\frac{2\pi d_b}{L_b}\right)$ (m)	$c_b = L_b/T$ (m/s)	s_i (m ³ /s)
1	0.06	-27.7	0.86	0.08	0.69	0.81	-0.00006
2	0.24	-25.6	1.92	0.31	3.15	1.64	-0.00184
3	0.34	-15.7	2.60	0.44	5.14	1.98	-0.00297
4	0.07	-50.7	0.91	0.09	0.79	0.87	-0.00010
5	0.20	-35.9	2.07	0.26	3.15	1.52	-0.00145
6	0.34	-23.6	2.80	0.44	5.57	1.99	-0.00421
7	0.08	56.8	3.30	0.10	3.29	1.00	0.00015
8	0.19	53.5	4.00	0.24	6.12	1.53	0.00132
9	0.09	70.0	1.24	0.12	1.25	1.01	0.00013
10	0.23	55.9	2.84	0.29	4.71	1.66	0.00204
11	0.36	49.7	3.90	0.46	8.13	2.08	0.00666
12	0.11	66.9	1.13	0.14	1.23	1.09	0.00024
13	0.29	53.2	2.66	0.37	4.90	1.84	0.00372
14	0.37	46.7	3.70	0.47	7.80	2.11	0.00720
15	0.09	44.4	1.11	0.12	1.11	1.00	0.00020
16	0.28	44.3	2.59	0.36	4.69	1.81	0.00354
17	0.38	39.6	3.55	0.49	7.56	2.13	0.00755
18	0.08	7.4	0.95	0.10	0.88	0.93	0.00004
19	0.26	11.3	2.08	0.33	3.57	1.71	0.00111
20	0.36	12.3	2.80	0.46	5.72	2.04	0.00275

The net transport is given by :

$$S_l = \sum_i^n s_{li} \cdot p_i$$

where S_l = net longshore transport (m^3/year)

s_{li} = longshore transport due to wave condition i

p_i = duration of occurrence of wave condition i in a year (s)

= % of time per year \times 31,536,000 s

Wave condition i	s_{li} (m^3/s)	Occurrence per year (%)	p_i (s)	S_l (m^3/year)
1	-0.00006	3.0	946,080	-57
2	-0.00184	3.8	1,198,368	-2,202
3	-0.00297	0.3	94,608	-281
4	-0.00010	3.7	1,166,832	-122
5	-0.00145	5.9	1,860,624	-2,689
6	-0.00421	0.4	126,144	-532
7	0.00015	1.9	599,184	88
8	0.00132	0.3	94,608	125
9	0.00013	1.5	473,040	62
10	0.00204	4.2	1,324,512	2,700
11	0.00666	0.1	31,536	210
12	0.00024	2.1	662,256	158
13	0.00372	1.2	378,432	1,407
14	0.00720	0.1	31,536	227
15	0.00020	1.5	473,040	95
16	0.00354	1.1	346,896	1,230
17	0.00755	0.3	94,608	714
18	0.00004	1.8	567,648	21
19	0.00111	1.5	473,040	525
20	0.00275	0.1	31,536	87
$\sum s_{li} =$				1,766

The total positive longshore transport quantity is +7,648 m^3/year and the total negative longshore transport quantity is -5,882 m^3/year . Therefore, the net longshore transport quantity is +1,766 m^3/year . The positive sign means that the net longshore transport direction is running towards the N 56° E direction.

(Note: Other longshore transport formulae may also be used to compute the longshore transport.)

B.4 EQUILIBRIUM SHORELINE ORIENTATION

Reference Section 5.5.3.

Given

The same data as given in Example B.3.

Find

The resultant wave angle of incoming waves and equilibrium shoreline orientation.

Solution

By following the approach in Example B.3 and assuming the wave height and wave angle at breaker line remain unchanged, the net longshore transportation rates for shoreline orientation varying from 32° to 56° N were determined in the following table:

Shoreline orientation (degree N)	Net longshore transport (m ³ /year)
32	-1,428
34	-1,169
36	-905
38	-636
40	-363
42	-89
44	185
46	459
48	730
50	998
52	1,260
54	1,517
56	1,766

The longshore transport rates at different shoreline orientations are plotted against the shoreline orientations in the following graph.

Variation of net longshore transport with shoreline orientation

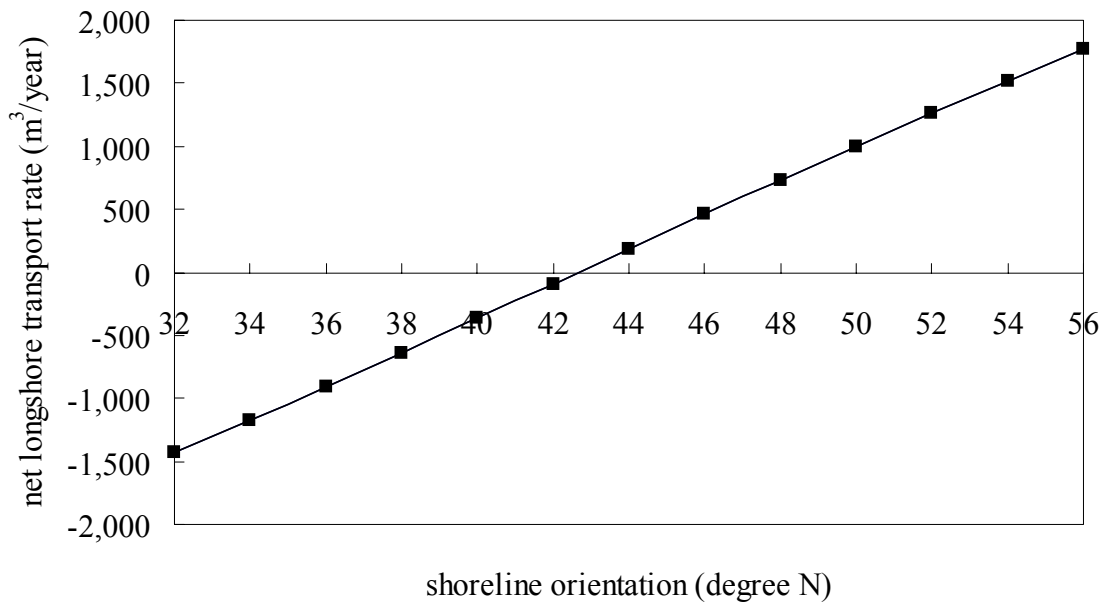

From the graph, it can be observed that the net transport rate will be equal to zero m³/year when the shoreline orientation is about 43°. The direction of net longshore transport calculated in Example B.3 indicates that the resultant wave angle should be on the left hand side of the shore normal. This also means that the resultant wave angle of the incoming waves given in Example B.3 is 133° as it should be normal to the equilibrium orientation.

B.5 EQUILIBRIUM PLAN FORM

Reference Section 5.5.5.

Given

The same data as given in Example B.3. The resultant incoming wave angle of the wave climate is 133° from the north.

Find

Determine the equilibrium beach plan form and layout of sand retaining structures at a shore running 56° from the north. The required minimum beach width at mean sea level is 30 m. The required beach length is about 250 m.

Solution

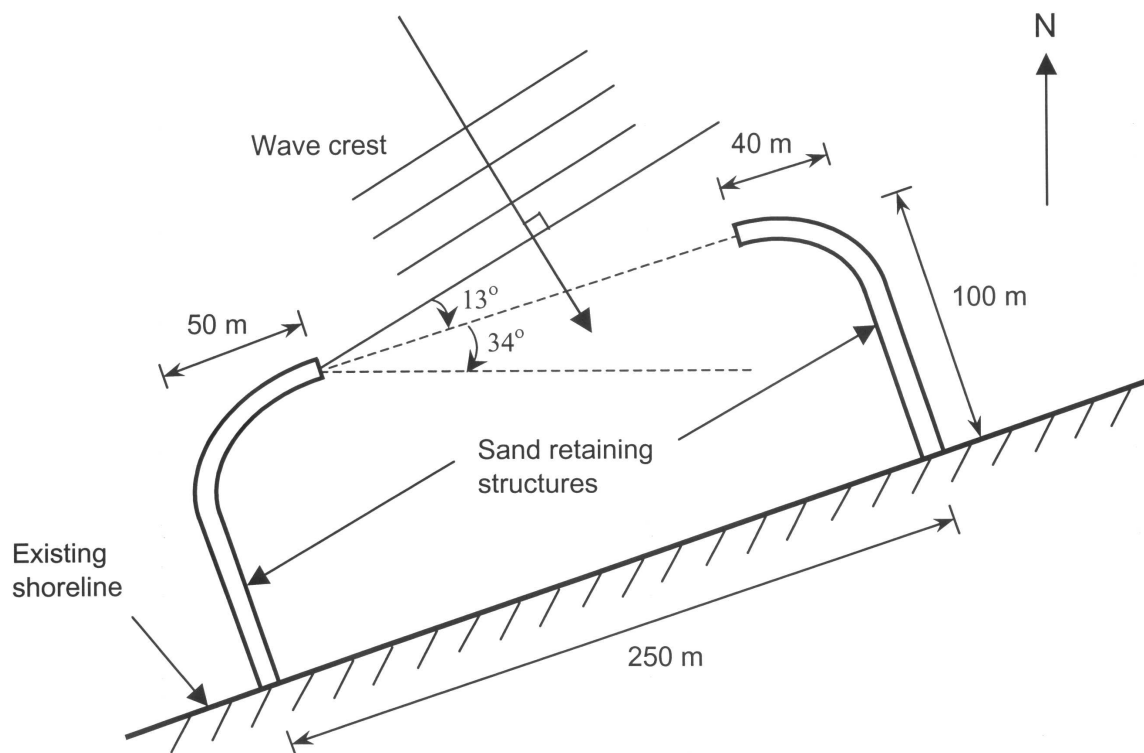

The method given in Section 5.5.5(3) and Figure 15 is applied to illustrate the design principle. The determination of the equilibrium plan form of the beach and the layout of sand retaining structures is a trial and error process. An initial assumed R_0 and structure layout is required, followed by subsequent refinement until the minimum beach width requirement is achieved. The layout as shown above is investigated in this worked example.

Trial 1

Assume $R_o = 175.0$ m

$$AB = 250.0 - 50.0 - 40.0 = 160.0 \text{ m}$$

$$BC = 160.0 \cos 13^\circ = 155.9 \text{ m}$$

$$\cos \beta = \frac{BC}{R_o} = \frac{155.9}{175.0} = 0.89$$

$$\beta = 27.0^\circ$$

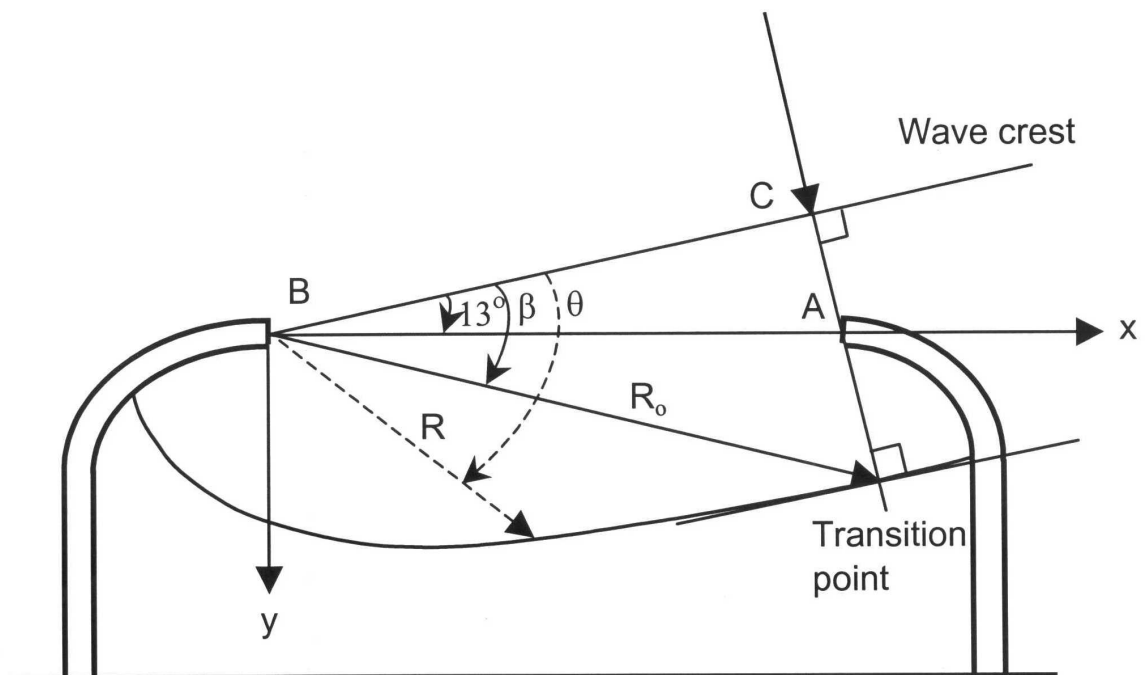

Compute the equilibrium plan form.

$$R_o = 175.0 \text{ m and } \beta = 27.0^\circ$$

$$x = R \cos (\theta - 13^\circ)$$

$$y = R \sin (\theta - 13^\circ)$$

θ (degree)	R/R_o [see Figure 15]	R (m)	x (m)	y (m)
27	1.00	175.0	169.8	42.4
37	0.79	138.4	126.4	56.3
47	0.64	111.3	92.2	62.3
57	0.54	95.2	68.4	66.1
67	0.48	84.0	49.3	67.9
77	0.43	75.0	32.8	67.4
87	0.38	66.3	18.3	63.8
97	0.35	60.7	6.3	60.4
107	0.32	56.4	-4.0	56.3
117	0.30	52.1	-12.6	50.5
127	0.28	49.4	-20.1	45.1
137	0.27	47.4	-26.5	39.3
147	0.26	45.4	-31.6	32.7
157	0.25	43.3	-35.0	25.4
167	0.23	41.0	-36.9	18.0
170	0.23	40.3	-37.2	15.5

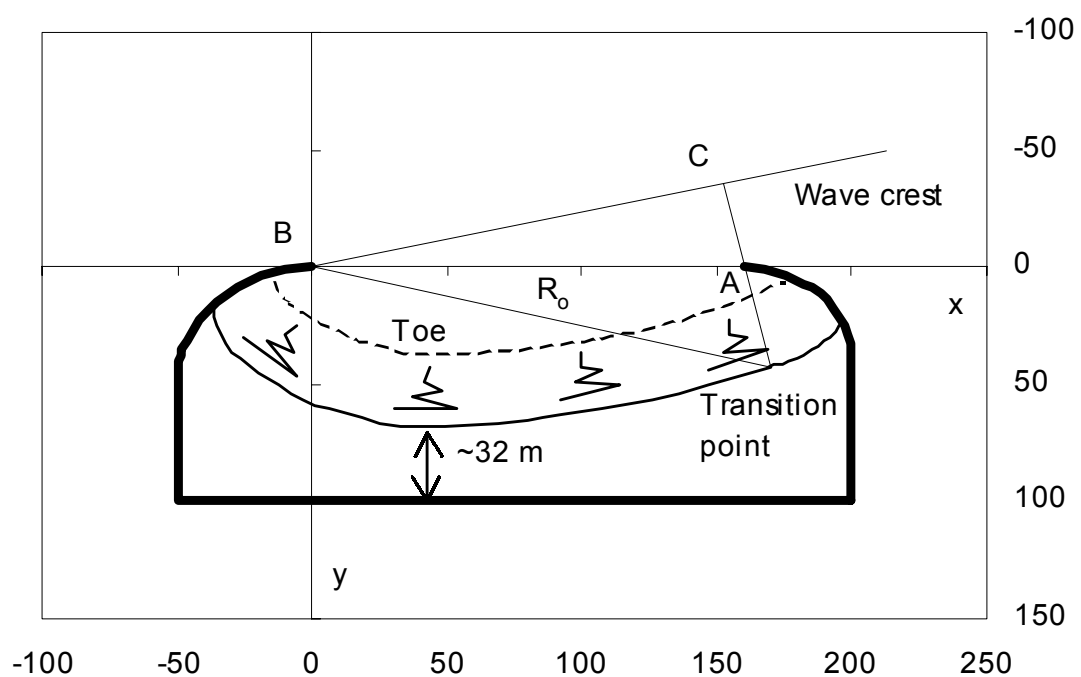

For the portion of the beach beyond the transition point, i.e., with angle $\theta < \beta$, Figure 15 provides no information about the arc ratio of the equilibrium bay shape. But as the waves will diffract around the upcoast headland, this portion of the beach could be assumed to be a circular arc with its centre located at point A and radius equal to the distance between the transition point and point A.

The above plan form with a maximum value of $y = 67.9$ m can satisfy the minimum beach width requirement of 30 m. Additional trials can be made if the exact minimum width of 30 m is required.

In addition, the design should ensure the toe of the beach lies within the sand retaining structures. Otherwise, sand loss may occur. The location of the toe may be estimated from the slope of equilibrium beach profile; methods to determine the equilibrium beach profile are shown in Examples B.1 and B.2.

The sand quantity required to achieve the minimum width of 30 m may then be estimated from the equilibrium plan form and the equilibrium profile within the sand retaining structures. A number of trials may need to be carried out to determine the optimal design layout.

GLOSSARY OF TERMS AND SYMBOLS

GLOSSARY OF TERMS

Backshore. The zone of the shore or beach lying between the upper limit of ordinary wave wash at high tide and the coastline.

Beach nourishment. The placement of sand fill to create a new beach or to widen an existing beach for recreation or shore protection purpose.

Berm. A nearly horizontal part of the beach or backshore formed by the deposit of sediment by wave action.

Breaker line. The line marking the area where large waves break.

Closure depth. The depth beyond which no significant net sediment transport occurs over a long time span.

Construction profile. The cross-shore profile of placed fill during beach nourishment.

Cross-shore transport. The onshore-offshore movement of sediment in the direction perpendicular to the shoreline due to wave breaking.

Detached breakwater. Breakwater constructed parallel to the shoreline but not connected to the shoreline.

Equilibrium beach profile. The cross-shore profile of the beach averaged over a long period.

Equilibrium shoreline orientation. The shoreline orientation with zero net longshore transport.

Foreshore. The beach face between the mean low water level and the upper limit of ordinary wave wash at high tide.

Groin. Long, narrow structure normally constructed perpendicular from the shoreline.

Littoral zone. The area where sediment transport takes place due to wave breaking and shear stress induced by wave motions at seabed.

Longshore transport. The movement of sediment in the direction parallel to the shoreline due to wave breaking.

Nearshore zone. A zone extending seaward from the shoreline well beyond the breaker zone.

Offshore zone. The zone beyond the nearshore zone.

Sand retaining structures. Beach protection structures constructed to physically prevent the sand from being lost from a beach.

Shoreline. The line of demarcation between a specified plane of water and the exposed beach face.

Sill. Underwater structure to support the toe of a beach.

Surf zone. The zone that extends seawards from the shoreline and the outmost breaker.

Swash zone. The beach face between the mean low water level and the upper limit of wave uprush.

GLOSSARY OF SYMBOLS

A	Dimensional factor (unit : $m^{1/3}$) of Brunn's equilibrium beach profile
B	A constant in the CERC longshore transport formula
c_b	Wave velocity or phase velocity at the breaker line
c_o	Deepwater wave velocity or phase velocity
D	Grain size
D_{10}	Grain size such that 10% of the particles are smaller than that size
D_{50}	Median grain size
D_{90}	Grain size such that 90% of the particles are smaller than that size
d	Water depth
d_{oc}	Depth of closure
g	Acceleration due to gravity
H_b	Significant wave height at breaker line
H_s	Significant wave height
K_{rb}	Refraction coefficient at breaker line
L_B	Length of detached breakwater
p_i	Duration of occurrence of a wave condition in a year
S_l	Net longshore transport
s_l	Longshore transport due to a breaking wave
s_{li}	Longshore transport of wave condition i
T_s	Significant wave period
y	Distance from shoreline
y_B	Distance of detached breakwater from shoreline
y_s	Amplitude of salient within a detached breakwater
ϕ_b	Wave angle relative to shore normal at breaker line

